

**Building Regulations (Part L Amendment) Regulations 2008 (S.I. No. 259 of 2008)
Technical Guidance Document L – Conservation of Fuel and Energy – Dwellings**

Introduction

In 2007, an amendment to Part L was made dealing only with dwellings (SI No. 854 of 2007), and an associated TGD L "Conservation of Fuel and Energy - Dwellings " dealing only with dwellings was published.

In 2008, an amendment to Part L was made to introduce the energy and CO₂ calculation methodology for buildings other than dwellings (SI No. 259 of 2008). This amendment also took the opportunity to consolidate all Part L amendments since 1997, thus revoking all previous amendments (i.e. SI No. 873 of 2005, SI No. 854 of 2007 etc).

As a result, TGD L "Conservation of Fuel and Energy - Dwellings" 2007 needs to be amended as set out in the table below. There are also some other minor amendments and corrections included.

Amd. No.	Text Affected
L(i)	Cover Page , Building Regulations 2007 to read Building Regulations 2008
L(ii)	Inside Cover Page , Building Regulations 2007 to read Building Regulations 2008
L(iii)	Page 3, Introduction , line 6 to read: Building Regulations (Part L Amendment) Regulations 2008 (S.I. No. 259 of 2008).
L(iv)	Page 3, Transitional Arrangements , replace 1 July 2009 with 30 June 2009
L(v)	<p>Page 5, Building Regulations – The Requirement, line 2 to read: Building Regulations (Part L Amendment) Regulations 2008 (S.I. No. 259 of 2008). The Second Schedule to read</p> <p align="center">Conservation of Fuel and Energy</p> <p>L1 A building shall be designed and constructed so as to ensure that the energy performance of the building is such as to limit the amount of energy required for the operation of the building and the amount of CO₂ emissions associated with this energy use insofar as is reasonably practicable.</p> <p>L2 For existing dwellings, the requirements of L1 shall be met by:</p> <ul style="list-style-type: none"> (a) limiting heat loss and, where appropriate, maximising heat gain through the fabric of the building; (b) controlling, as appropriate, the output of the space heating and hot water systems; (c) limiting the heat loss from pipes, ducts and vessels used for the transport or storage of heated water or air; (d) providing that all oil and gas fired boilers installed in existing dwellings shall meet a minimum seasonal efficiency of 86% where practicable. <p>L3 For new dwellings, the requirements of L1 shall be met by:</p> <ul style="list-style-type: none"> (a) providing that the energy performance is such as to limit the calculated primary energy consumption and related CO₂ emissions insofar as is reasonably practicable, when both energy consumption and CO₂ emissions are calculated using the Dwelling Energy Assessment Procedure (DEAP) published by Sustainable Energy Ireland; (b) providing that a reasonable proportion of the energy consumption to meet the energy performance of a dwelling is provided by renewable energy sources; (c) limiting heat loss and, where appropriate, availing of heat gain through the fabric of the dwelling; (d) providing and commissioning energy efficient space and water heating systems with efficient heat sources and effective controls; (e) providing to the dwelling owner sufficient information about the dwelling, the fixed building services and their maintenance requirements so that the dwelling can be operated in such a manner as to use no more fuel and energy than is reasonable; (f) providing that all oil and gas fired boilers shall meet a minimum seasonal efficiency of 86%.
L(vi)	Paragraph 0.1.2 , replace Regulation L2(a) with Regulation L3(a)

L(vii)	Paragraph 0.1.7 , replace Regulation L3 with Regulation L2(d)
L(viii)	<p>Paragraph 0.5, at end of Definitions, add: 0.5.1 APPLICATION TO BUILDINGS OF ARCHITECTURAL OR HISTORICAL INTEREST</p> <p>Part L does not apply to works (including extensions) to an existing building which is a “protected structure” or a ‘proposed protected structure’ within the meaning of the Planning and Development Act 2000 (No 30 of 2000).</p> <p>Nevertheless, the application of this Part may pose particular difficulties for habitable buildings which, although not protected structures or proposed protected structures, may be of architectural or historical interest.</p> <p>Works such as the replacement of doors, windows and rooflights, the provision of insulated dry lining and damp-proofing to walls and basements, insulation to the underside of slating and provision of roof vents and ducting of pipework could all affect the character of the structure.</p> <p>In general, the type of works described above should be carefully assessed for their material and visual impact on the structure.</p> <p>Historic windows and doors should be repaired rather than replaced, and drylining and dampproofing should not disrupt or damage historic plasterwork or flagstones and should not introduce further moisture into the structure.</p> <p>Roof insulation should be achieved without damage to slating (either during the works or from erosion due to condensation) and obtrusive vents should not affect the character of the roof.</p> <p>In specific cases, relaxation of the values proposed may be acceptable, to the local building control authority, if it can be shown to be necessary in order to preserve the architectural integrity of the particular building.</p> <p>For more guidance on appropriate measures see “Planning Guidelines No. 9: Architectural Heritage Protection - Guidelines for Planning Authorities” published by the Department of the Environment, Heritage and Local Government.</p>
L(ix)	Paragraph 1.1.1 , replace Regulation L2(a) with Regulation L3(a)
L(x)	Paragraph 1.1.2 , replace Regulation L2(a) with Regulation L3(a)
L(xi)	Paragraph 1.2.1 , line 3 and last line, replace Regulation L2(b) with Regulation L3(b)
L(xii)	Paragraphs 1.3.2.2; 1.4.1.1; 1.5.5.1; 2.1.2.2; 2.2.1.1; 2.2.2.1 & Other Publications , replace (to be published) with (available on www.environ.ie)
L(xiii)	Paragraph 1.4.1.1 , replace Regulation L2(d) with Regulation L3(d) and replace Regulation L2(e) with Regulation L3(f)
L(xiv)	Paragraphs 1.4.4.3; 2.2.4.3 and Standards referred to: replace –400°C with –40°C
L(xv)	Paragraph 1.3.3.2 (b) , to read: Adopt details that are similar to, or demonstrated as equivalent to, generic details that have been assessed as limiting thermal bridging to an equivalent level to that set out in Table D1 of Appendix D. A set of such details for typical constructions has been developed in consultation with relevant construction industry organisations and is available in a document “ <i>Limiting Thermal Bridging and Air Infiltration – Acceptable Construction Details</i> ” (available on www.environ.ie). The procedure for assessing the performance of specific details is outlined in <u>Appendix D</u> .
L(xvi)	Paragraph 1.5.4.7 , in second last sentence replace Paragraph 1.3.4.3 with Paragraph 1.3.4.4
L(xvii)	Paragraph 2.1.3.2 , second paragraph to read: Adopt details that are similar to, or demonstrated as equivalent to, generic details that have been assessed as limiting thermal bridging to an equivalent level to that set out in Table D1 of Appendix D. A set of such details for typical constructions has been developed in consultation with relevant construction industry organisations and is available in a document “ <i>Limiting Thermal Bridging and Air Infiltration – Acceptable Construction Details</i> ” (available on www.environ.ie).
L(xviii)	Paragraph 2.2.1.1 , replace Regulation L3 with Regulation L2(d)
L(xix)	A.4.1, Table A4: replace 0.23 with 0.28 and insert new item as follows “Facing wall not exposed, corridor above and below 0.40”
L(xx)	B.7.1, Table 18 to read Table B18
L(xxi)	B.7.1, Tables B19, B20 & B21 , replace column heading “Total Thickness of insulation (mm)” with “Exposed Perimeter/Area (P/A)(m-1)” and replace text “W-Value of construction (W/m ² K)” with “Total thickness of insulation (mm)”
L(xxii)	Paragraph C.1 , replace Regulation L2(a) with Regulation L3(a)
L(xxiii)	D.4 replace BRE IP 1/07 with BRE IP 1/06

Conservation of Fuel and Energy - Dwellings



Building Regulations 2007

Technical Guidance Document



Comhshaol, Oidhreachta agus Rialtas Áitiúil
Environment, Heritage and Local Government



Building Regulations 2007

Technical Guidance Document L

Conservation of Fuel and Energy - Dwellings

ARNA FHOILSIÚ AG OIFIG AN tSOLÁTHAIR
BAILE ÁTHA CLIATH

Le ceannach díreach ón
OIFIG DHIOLTA FOILSEACHÁN RIALTAIS
TEACH SUN ALLIANCE, SRÁID THEACH LAIGHEAN, BAILE ÁTHA CLIATH 2,
nó tríd an bpost ó
FOILSEACHÁN RIALTAIS, AN RANNÓG POST-TRÁCHTA,
AONAD 20 PÁIRC MIONDÍOLA COIS LOCHA, CLÁR CHLAINNE MHIRIS, CONTAE MHAIGH EO
(Teil: 01 - 6476834/37 nó 1890 213434; Fax: 01 - 6476843 nó 094 9378964)
nó trí aon díoltóir leabhar.

PUBLISHED BY THE STATIONERY OFFICE
DUBLIN

To be purchased directly from the
GOVERNMENT PUBLICATIONS SALE OFFICE
SUN ALLIANCE HOUSE, MOLESWORTH STREET, DUBLIN 2,
or by mail order from
GOVERNMENT PUBLICATIONS, POSTAL TRADE SECTION,
UNIT 20 LAKESIDE RETAIL PARK, CLAREMORRIS, CO. MAYO
(Tel: 01 - 6476834/37 or 1890 213434; Fax: 01 - 6476843 or 094 9378964)
or through any bookseller.

Price: €12.00

ISBN 978-1-4064-2123-1



Printed on recycled paper
containing a minimum of
75% post-consumer waste



Comhshaol, Oidhreacht agus Rialtas Áitiúil
Environment, Heritage and Local Government

© Government of Ireland 2008

Contents

	Page
Introduction	3
Transitional Arrangements	3
The Guidance	3
Technical Specifications	3
Materials and Workmanship	4
Interpretation	4
Part L - The Requirement	5
Section 0: General Guidance	
0.1 Application of the Regulations	7
0.1.2 New Dwellings	7
0.1.7 Existing Dwellings	8
0.2 Technical Risks and Precautions	9
0.2.1 General	9
0.2.2 Fire Safety	9
0.2.3 Ventilation	9
0.3 Thermal Conductivity and Thermal Transmittance	9
0.4 Dimensions	10
0.5 Definitions	11
Section 1: New Dwellings	
1.1 Limitation of Primary Energy Use and CO² Emissions	13
1.2 Renewable Energy Technologies	15
1.3 Building Fabric	17
1.3.1 General	17
1.3.2 Fabric Insulation	17
1.3.3 Thermal Bridging	19
1.3.4 Building Envelope Air Permeability	20
1.4 Building Services	21
1.4.1 General	21
1.4.2 Heating Appliance Efficiency	21
1.4.3 Space Heating and Hot Water Supply System Control	21
1.4.4 Insulation of Hot Water Storage Vessels, Pipes and Ducts	22
1.4.5 Mechanical Ventilation Systems	22

1.5	Construction Quality and Commissioning of Services	23
1.5.1	General	23
1.5.2	Insulation Continuity and Air Permeability	23
1.5.3	Thermal Bridging	23
1.5.4	Air Permeability Pressure Tests	23
1.5.5	Commissioning of Space and Water Heating Systems	24
1.6	User Information	25
Section 2: Existing Dwellings		
2.1	Building Fabric	27
2.1.1	General	27
2.1.2	Fabric Insulation	27
2.1.3	Thermal Bridging	29
2.1.4	Air Permeability	31
2.2	Building Services	32
2.2.1	General	32
2.2.2	Heating Appliance Efficiency	32
2.2.3	Space Heating and Hot Water Supply System Control	32
2.2.4	Insulation of Hot Water Storage Vessels, Pipes and Ducts	33
Appendices		
A	Calculation of U-values	35
B	Fabric Insulation: Additional Guidance for Common Constructions, including Tables of U-values	43
C	Reference Values for Calculation of Maximum Permitted Energy Performance Coefficient (MPEPC) and Maximum Permitted Carbon Performance Coefficient (MPCPC)	65
D	Thermal Bridging at Junctions and around Openings	67
E	Achieving Compliance with respect to EPC and CPC	69
STANDARDS AND OTHER REFERENCES		71

Building Regulations 2007

Technical Guidance Document L

Conservation of Fuel and Energy – Dwellings

Introduction

This document has been published by the Minister for the Environment, Heritage and Local Government under article 7 of the Building Regulations 1997. It provides guidance in relation to the application of Part L of the Second Schedule to the Regulations as inserted by **Building Regulations (Amendment) Regulations 2007 (S.I. No. 854 of 2007)**. The guidance in this document applies to dwellings, both new and existing. The guidance in relation to the application of Part L contained in Technical Guidance Document L - Conservation of Fuel and Energy (May 2006 Edition) continues to apply to all other new and existing buildings.

The document should be read in conjunction with the Building Regulations 1997-2007 and other documents published under these Regulations.

In general, Building Regulations apply to the construction of new buildings and to extensions and material alterations to existing buildings. In addition, certain Parts of the Regulations, including Part L, apply to existing buildings where a material change of use takes place.

Transitional Arrangements

In general, this document applies to works to new dwellings, where the work commences or takes place, as the case may be, on or after 1 July 2008. Insofar as the guidance contained therein relates to dwellings, Technical Guidance Document L - Conservation of Fuel and Energy (2006 Edition) ceases to have effect from 1 July 2008.

However, the foregoing document may continue to be used in the case of dwellings:

- where the work, material alteration or the change of use commences or takes place, as the case may be, on or before 30 June 2008, or
- where planning approval or permission has been applied for on or before 30 June 2008, and substantial work has been completed by 1 July 2009.

Where the works involve the installation of oil or gas fired boilers in either a new or existing dwelling, the relevant aspects of this guidance applies to works undertaken after the 31 March 2008.

Substantial work has been completed” means that the structure of the external walls has been erected.

The Guidance

The materials, methods of construction, standards and other specifications (including technical specifications) that are referred to in this document are those which are likely to be suitable for the purposes of the Building Regulations (as amended). Where works are carried out in accordance with the guidance in this document, this will, prima facie, indicate compliance with Part L of the Second Schedule to the Building Regulations.

However, the adoption of an approach other than that outlined in the guidance is not precluded provided that the relevant requirements of the Regulations are complied with. Those involved in the design and construction of a building may be required by the relevant building control authority to provide such evidence as is necessary to establish that the requirements of the Regulations are being complied with.

Technical Specifications

Building Regulations are made for specific purposes, e.g. to provide, in relation to buildings, for the health, safety and welfare of persons, the conservation of energy, and access for people with disabilities.

Technical specifications (including harmonised European Standards, European Technical Approvals, National Standards and Agreement Certificates) are relevant to the extent that they relate to these considerations.

Any reference to a technical specification is a reference to so much of the specification as is relevant in the context in which it arises. Technical specification may also address other aspects not covered by the Regulations.

A reference to a technical specification is to the latest edition (including any amendments, supplements or addenda) current at the date of publication of this Technical Guidance Document. However, if this version of the technical specification is subsequently revised or updated by the issuing body, the new version may be used as a source of guidance provided that it continues to address the relevant requirements of the Regulations.

Materials and Workmanship

Under Part D of the Second Schedule to the Building Regulations, building work to which the Regulations apply must be carried out with proper materials and in a workmanlike manner. Guidance in relation to compliance with Part D is contained in Technical Guidance Document D.

Interpretation

In this document, a reference to a section, paragraph, appendix or diagram is, unless otherwise stated, a reference to a section, paragraph, appendix or diagram, as the case may be, of this document. A reference to another Technical Guidance Document is a reference to the latest edition of a document published by the Department of the Environment, Heritage and Local Government under article 7 of the Building Regulations 1997.

Diagrams are used in this document to illustrate particular aspects of construction - they may not show all the details of construction.

Conservation of Fuel and Energy

Building Regulations - The Requirement

The requirements regarding conservation of fuel and energy for dwellings are laid out in Part L of the Second Schedule to the Building Regulations 1997 (S.I. No. 497 of 1997) as amended by the Building Regulations (Amendment) Regulations 2007 (S.I. No. 854 of 2007).

The Second Schedule, insofar as it relates to works relating to dwellings, is amended to read as follows:

Conservation of Fuel and Energy

- L1 A dwelling shall be designed and constructed so as to ensure that the energy performance of the building is such as to limit the amount of energy required for the operation of the dwelling and the amount of CO₂ emissions associated with this energy use insofar as is reasonably practicable.
- L2 For new dwellings, the requirement of L1 shall be met by
- a. providing that the energy performance of the dwelling is such as to limit the calculated primary energy consumption and related CO₂ emissions insofar as is reasonably practicable, when both energy consumption and CO₂ emissions are calculated using the Dwelling Energy Assessment Procedure (DEAP) published by Sustainable Energy Ireland;
 - b. providing that, for new dwellings, a reasonable proportion of the energy consumption to meet the energy performance of a dwelling is provided by renewable energy sources;
 - c. limiting heat loss and, where appropriate, availing of heat gain through the fabric of the building;
 - d. providing and commissioning energy efficient space and water heating systems with efficient heat sources and effective controls;
 - e. providing that all oil and gas fired boilers shall meet a minimum seasonal net efficiency of 86%;
 - f. providing to the dwelling owner sufficient information about the building, the fixed building services and their maintenance requirements so that the building can be operated in such a manner as to use no more fuel and energy than is reasonable
- L3 All oil and gas fired boilers installed as replacements in existing dwellings shall meet a minimum seasonal net efficiency of 86% where practicable.

Section 0: General Guidance

0.1: Application of the Regulations

0.1.1 The aim of Part L of the Second Schedule to the Building Regulations is to limit the use of fossil fuel energy and related CO₂ emissions arising from the operation of buildings, while ensuring that occupants can achieve adequate levels of lighting and thermal comfort. Buildings should be designed and constructed to achieve this aim as far as is practicable.

This amendment of the Regulations amends the requirements of Part L insofar as they relate to dwellings and the guidance in this Document applies to works to dwellings only. This Document does not apply to works to buildings other than dwellings, including material alterations and material change of use to such buildings. The 2006 edition of TGD L continues to apply in these cases.

New Dwellings

0.1.2 For new dwellings, the key issues to be addressed in order to ensure compliance are:

- (a) Primary Energy Consumption and related CO₂ emissions: providing that the calculated primary energy consumption associated with the operation of the dwelling and the related CO₂ emissions, as described in Section 1.1, do not exceed a target value specified in this document
- (b) Use of Renewable Energy Sources: providing that the contribution of low or zero carbon energy sources to the calculated primary energy requirement meets the target for such contribution set down in Section 1.2
- (c) Fabric insulation: providing for fabric insulation, including the limitation of cold bridging, which satisfies the guidance in this regard set out in Section 1.3 (Sub-sections 1.3.2 to 1.3.4)
- (d) Air Tightness: limiting air infiltration as set out in Sub-section 1.3.4
- (e) Boiler efficiency: providing an efficient boiler or other heat source as set out in Sub-section 1.4.2
- (f) Building Services Controls: controlling, as appropriate the demand for and output of

space heating and hot water services provided, as set out in Sub-section 1.4.3

- (g) Insulation of Pipes, Ducts and Vessels: limiting the heat loss from pipes, ducts and vessels used for the transport or storage of heated water or air, as set out in Sub-section 1.4.4
- (h) Mechanical Ventilation Systems: providing that, where a mechanical ventilation system is installed, the system meets reasonable performance levels, as set out in Sub-section 1.4.5
- (i) Performance of Completed Dwelling: Ensure design and construction process are such that completed building satisfies compliance targets and design intent. Guidance is given in Section 1.5
- (j) User information: Ensure that adequate operating and maintenance instructions are available to facilitate operation in an energy efficient manner. Guidance is given in Section 1.6.

The principal aims of Part L of the Building Regulations are to limit primary energy consumption and associated CO₂ emissions. The performance levels specified for items (b) to (i) above are in the nature of backstop minimum performance levels so as to ensure reasonable levels of performance for all factors affecting energy use, irrespective of the measures incorporated to achieve compliance with Regulation L2(a). Meeting the performance levels specified for items (b) to (i) will not necessarily mean that the level specified for primary energy consumption and related CO₂ emissions (item (a)) will be met. It is likely that one or more of the performance levels specified, for items (b) to (i), will need to be exceeded to achieve this.

0.1.3 This revision of Part L represents a significant step towards the optimisation of the efficiency of energy use in new dwellings and the minimisation of related CO₂ emissions. It is intended that the standards specified here will be tightened further in 2010. The aim is to achieve zero carbon emissions associated with the operation and use of dwellings, at the earliest date practicable.

0.1.4 Insofar as the current amendment does not achieve this target, the design and construction of dwellings complying with this amendment to Part L, should be carried out in such a manner as to facilitate, insofar as practicable, the future upgrading of the building fabric and fixed services so as to reduce further carbon emissions associated with the operation and use of these dwellings.

0.1.5 Where a dwelling has an attached room or space that is to be used for commercial purposes (e.g. workshop, surgery, consulting room or office), such room or space should be treated as part of the dwelling if the commercial part could revert to domestic use on a change of ownership, e.g. where there is direct access between the commercial space and the living accommodation, both are contained within the same thermal envelope and the living accommodation occupies a substantial proportion of the total area of the building.

Where a new dwelling forms part of a larger building, the guidance in this document applies to the individual dwelling, and the relevant guidance in Technical Guidance Document L- Conservation of Fuel and Energy (May 2006 Edition) applies to the non-dwelling parts of the building such as common areas (including common areas of apartment blocks), and in the case of mixed-use developments, the commercial or retail space.

0.1.6 The guidance given in this Technical Guidance Document is generally applicable to all works associated with the construction of new dwellings. However, unheated ancillary areas which are not intended for use as part of the habitable dwelling area should generally be treated as outside the area assessed in relation to energy consumption and CO₂ emissions (see Section 1.1). However, where such areas have the potential to become part of the habitable area, e.g. attached garages, the external fabric elements should comply with the guidance in relation to fabric insulation given in Sub-sections 1.3.2 and 1.3.3.

An attached conservatory-style sunspace, or the like, forming part of a new dwelling construction should be treated as an integral part of the habitable area of the dwelling.

Existing Dwellings

0.1.7 This amendment applies to all works to existing dwellings that are covered by the requirements of the Building Regulations, including extensions, material alterations, material changes of use and window and door replacement. In carrying out this work, the aim should be to limit energy requirements for the operation of the dwelling and associated CO₂ emissions as far as practicable as required by Regulation L1. Specifically, Regulation L3 provides that replacement oil and gas boilers should achieve a seasonal net efficiency of 86% where practicable. The key issues to be addressed are:

- (a) Fabric insulation: providing reasonable levels of fabric insulation in all new construction, including, where provided, replacement windows and doors. Guidance is given in Sub-section 2.1.2
- (b) Air Tightness: limiting air infiltration through the newly constructed elements as far as practicable. Guidance is given in Sub-section 2.1.4
- (c) Boiler Efficiency: providing an efficient boiler or other heat source as set out in Sub-section 2.2.2
- (d) Building Services Controls: where new space and/or water heating services are provided, controlling, as appropriate, the demand for and output of these space heating and hot water services. Guidance on appropriate measures is given in Sub-section 2.2.3
- (e) Insulation of Pipes, Ducts and Vessels: limiting the heat loss from pipes, ducts and vessels used for the transport or storage of heated water or air, as set out in Sub-section 2.2.4.

0.2 TECHNICAL RISKS AND PRECAUTIONS

General

0.2.1 The incorporation of additional thickness of thermal insulation and other energy conservation measures can result in changes in traditional construction practice. Care should be taken in design and construction to ensure that these changes do not increase the risk of certain types of problems, such as rain penetration and condensation.

Some guidance on avoiding such increased risk is given in Appendix B of this document. General guidance on avoiding risks that may arise is also contained in the publication “*Thermal insulation: avoiding risks; Building Research Establishment (Ref BR 262)*”.

Guidance in relation to particular issues and methods of construction will be found in relevant standards.

Fire Safety

0.2.2 Part B of the Second Schedule to the Building Regulations prescribes fire safety requirements. In designing and constructing buildings to comply with Part L, these requirements must be met and the guidance in relation to fire safety in TGD B should be fully taken into account. In particular, it is important to ensure that windows, which provide secondary means of escape in accordance with Section 1.5 of TGD B, comply with the dimensional and other guidance for such windows set out in Paragraph 1.5.6 of TGD B.

Ventilation

0.2.3 Part F of the Second Schedule to the Building Regulations prescribes ventilation requirements both to meet the needs of the occupants of the building and to prevent excessive condensation in roofs and roofspaces. A key aim of the provisions in relation to ventilation of occupied spaces is to minimise the risk of condensation, mould growth or other indoor air quality problems. In addition to meeting the requirements of Part F of the Building Regulations the avoidance of excessive condensation requires that appropriate heating and ventilation regimes be

employed in occupied dwellings. Advice for house purchasers and occupants on these issues is published separately by both HomeBond and Sustainable Energy Ireland. It is the intention to review TGD F to take account of the current revision of Part L.

Part J of the Second Schedule to the Building Regulations prescribes requirements in relation to the supply of air for combustion appliances, including open-flued appliances which draw air from the room or space in which they are situated. TGD J provides guidance in this regard.

0.3 THERMAL CONDUCTIVITY AND THERMAL TRANSMITTANCE

0.3.1 Thermal conductivity (λ -value) relates to a material or substance, and is a measure of the rate at which heat passes through a uniform slab of unit thickness of that material or substance, when unit temperature difference is maintained between its faces. It is expressed in units of Watts per metre per degree (W/mK).

0.3.2 For the purpose of showing compliance with this Part of the Building Regulations, design λ -values based on manufacturers declared values should be used. For thermally homogeneous materials, declared and design values should be determined in accordance with I.S. EN ISO 10456: 1997. Design values for masonry materials should be determined in accordance with I.S. EN 1745: 2002. For insulation materials, values determined in accordance with the appropriate harmonized European standard should be used. Certified λ -values for foamed insulant materials should take account of the blowing agent actually used. The use of HCFC for this purpose is no longer permitted.

For products or components for which no appropriate standard exists, measured values, certified by an approved body or certified laboratory (see TGD D), should be used.

0.3.3 Tables A1 and A2 of Appendix A contain λ values for some common building materials and insulation materials. These are primarily based on data contained in I.S. EN 12524: 2000 or in CIBSE Guide A, Section A3. The values provide a general indication of the thermal conductivity that may be

expected for these materials. In the absence of declared values, design values or certified measured values as outlined in Paragraph 0.3.2, values of thermal conductivity given in [Table A1](#) may be used. However, values for specific products may differ from these illustrative values. Indicative λ -values for thermal insulation materials are given in [Table A2](#). These may be used at early design stage for the purpose of assessing likely compliance with this Part of the Regulations. However, compliance should be verified using thermal conductivity values for these materials derived as outlined in Paragraph 0.3.2 above.

0.3.4 Thermal transmittance (U-value) relates to a building component or structure, and is a measure of the rate at which heat passes through that component or structure when unit temperature difference is maintained between the ambient air temperatures on each side. It is expressed in units of Watts per square metre per degree of air temperature difference ($\text{W}/\text{m}^2\text{K}$).

0.3.5 Thermal transmittance values (U-values) relevant to this Part of the Regulations are those relating to elements exposed directly or indirectly to the outside air. This includes floors directly in contact with the ground, suspended ground floors incorporating ventilated or unventilated voids, and elements exposed indirectly via unheated spaces. The U-value takes account of the effect of the ground, voids and unheated spaces on the rate of heat loss, where appropriate. Heat loss through elements that separate dwellings or other premises that can reasonably be assumed to be heated, is considered to be negligible. Such elements do not need to meet any particular U-value nor should they be taken into account in calculation of CO_2 emissions or overall transmission heat loss.

0.3.6 A range of methods exists for calculating U-values of building elements. Methods of calculation are outlined in [Appendix A](#), together with examples of their use. Alternatively U-values may be based on certified measured values. Measurements of thermal transmission properties of building components generally should be made in accordance with I.S. EN ISO 8990: 1997, or, in the case of windows and doors, I.S. EN ISO 12567-1: 2001.

0.3.7 Any part of a roof that has a pitch of 70° or more may be treated as a wall for the purpose of assessing the appropriate level of thermal transmission. Elements separating the building from spaces that can reasonably be assumed to be heated should not be included.

0.3.8 [Appendix B](#) contains tables of indicative U-values for certain common constructions. These are derived using the calculation methods referred to in [Appendix A](#), and may be used in place of calculated or measured values, where appropriate. These tables provide a simple way to establish the U-value for a given amount of insulation. Alternatively they may be used to establish the amount of insulation needed to achieve a given U-value. The values in the tables have been derived taking account of typical repeated thermal bridging where appropriate. Where an element incorporates a non-repeating thermal bridge, e.g. where the continuity of insulation is broken or penetrated by material of reduced insulating quality, the U-value derived from the table should be adjusted to account for this thermal bridge. [Table B23](#) in [Appendix B](#) contains indicative U-values for external doors, windows and rooflights (roof windows).

0.4 DIMENSIONS

0.4.1 Except where otherwise indicated linear measurements for the calculation of wall, roof and floor areas and building volumes should be taken between the finished internal faces of the appropriate external building elements and, in the case of roofs, in the plane of the insulation. Linear measurements for the calculation of the areas of external door, window and rooflight openings should be taken between internal faces of appropriate cills, lintels and reveals.

0.4.2 "Volume" means the total volume enclosed by all enclosing elements and includes the volume of non-usable spaces such as ducts, stairwells and floor voids in intermediate floors.

0.5 DEFINITIONS

For the purposes of this Technical Guidance Document the following definitions apply:

Energy Use (for a particular purpose e.g. space heating, water heating, water heating, cooling, ventilation, lighting): Energy input to the relevant system to satisfy the relevant purpose.

Delivered Energy: Energy supplied to the dwelling and its systems to satisfy the relevant energy uses e.g. space heating, water heating, cooling, ventilation, lighting. Delivered energy does not include renewable energy produced on site.

Delivered energy differs from energy use by the extent of on-site conversion and transformation losses e.g. boiler efficiency losses

Primary Energy: Energy that has not been subjected to any conversion or transformation process. For a dwelling, it is the delivered energy plus the energy used to produce the energy delivered to the dwelling. It is calculated from the delivered energy, with an allowance for any energy exported from the site, using conversion factors.

Renewable Energy: Energy from renewable non-fossil energy sources e.g. solar energy (thermal and photovoltaic), wind, hydropower, biomass, geothermal, wave, tidal, landfill gas, sewage treatment plant gas and biogases.

Biomass: Biodegradable fraction of products, waste and residues from agriculture (including vegetal and animal substances), forestry and related industries, as well as biodegradable fraction of industrial and municipal waste, used as a fuel or energy source. Fuels derived from biomass may be in solid, liquid or gas form. In this document, where the term “biomass” is used on its own, it should be taken to mean solid biomass (wood, wood chip, wood pellet, etc).

Biofuel: Liquid or gas fuel derived from biomass.

Seasonal Net Efficiency: The seasonal efficiency calculated as defined in the DEAP manual.

Note: *Biomass* (including biofuel) is generally included in *Delivered Energy* and thus, together with the energy used to produce and deliver it, included in *Primary Energy*.

Section 1: New Dwellings

1.1: Limitation of Primary Energy Use and CO₂ Emissions

1.1.1 This Section provides guidance on how to show compliance with the requirements in relation to primary energy consumption and CO₂ emissions specified in Regulation L2(a). The methodology for calculation to be used is specified in the Regulation as the DEAP methodology. This methodology is published by Sustainable Energy Ireland (SEI) and calculates the energy consumption and CO₂ emissions associated with a standardised use of a dwelling. The energy consumption is expressed in terms of kilowatt hours per square metre floor area per year (kWh/m²/yr) and the CO₂ emissions expressed in terms of kilograms of CO₂ per square metre floor area per year (kg CO₂/m²/yr). Full details of the methodology are available on the SEI website at <http://www.sei.ie>.

1.1.2 The performance criteria are based on the relative values of the calculated primary energy consumption and CO₂ emissions of a dwelling being assessed, and similar calculated values for a Reference Dwelling. Details of the Reference Dwelling are given in [Appendix C](#). The criteria are determined as follows:

- Primary energy consumption and CO₂ emissions for both the proposed dwelling and the reference dwelling are calculated using DEAP.
- The calculated primary energy consumption of the proposed dwelling is divided by that of the reference dwelling, the result being the energy performance coefficient (EPC) of the proposed dwelling. To demonstrate that an acceptable Primary Energy consumption rate has been achieved, the calculated EPC of the dwelling being assessed should be no greater than the Maximum Permitted Energy Performance Coefficient (MPEPC). The MPEPC is 0.6.
- The calculated carbon dioxide emission rate of the proposed dwelling is divided by that of the reference dwelling, the result being the carbon performance coefficient (CPC) of the proposed dwelling. To demonstrate that an acceptable Carbon Dioxide emission rate has been achieved, the calculated CPC of the dwelling being assessed should be no greater than the Maximum Permitted Carbon Performance Coefficient (MPCPC). The MPCPC is 0.69.

The DEAP software will calculate the EPC and CPC of the dwelling being assessed and clearly indicate whether compliance with the requirements of Regulation L2 (a) has been achieved.

1.1.3 Where a building contains more than one dwelling (such as in a terrace of houses or a block of apartments), reasonable provision would be to show that:

- every individual dwelling has an EPC and CPC no greater than the MPEPC and MPCPC respectively, or
- the average EPC and CPC for all dwellings in the building is no greater than the MPEPC and MPCPC respectively.

Where the latter approach is used, the average EPC and CPC are calculated by multiplying the EPC and CPC for each individual dwelling by the floor area of that dwelling, adding together and dividing the results by the sum of the floor areas of all dwellings. Common areas in the building are not included in this calculation.

1.1.4 The requirements that the calculated EPC and CPC do not exceed the calculated MPEPC and MPCPC respectively, applies to the constructed dwelling. Designers may wish to calculate the EPC and CPC at early design stage in order to ensure that the requirements can be achieved by the constructed building. It is also open to professional bodies or other industry interests to develop model dwelling designs that can confidently be adopted without the need to calculate the EPC and CPC at design stage. However, the use of constructions and service systems which have been assessed at design stage, or other model designs, does not preclude the need to verify compliance by calculating the EPC and CPC when all relevant details of the final construction are known.

1.1.5 The use of renewable and low carbon technologies, such as solar hot water, biomass (e.g. wood and wood pellets) and heat pumps, whether provided to meet the requirements of this Part of the Building Regulations (see Section 1.2) or provided as additional to meeting that requirement, can facilitate compliance with the requirements in relation to primary energy use and CO₂ emissions. As defined, primary energy does not include energy

derived from on-site renewable energy technologies. In addition, as renewable energy technologies generally are characterised by zero, or greatly reduced, CO₂ emissions, the calculated EPC and CPC are reduced by the extent that they replace traditional fossil fuels. As the performance of the Reference Dwelling (see [Appendix C](#)) is not affected by the incorporation of these technologies in a dwelling being assessed, this has the effect of making it easier to achieve compliance with this Part of the Building Regulations when these technologies are used.

For certain dwelling types, use of renewables may prove the most practical approach to achieving compliance. The use of centralised renewable energy sources contributing to a heat distribution system serving all dwelling units in a development or apartment block may prove to be more practicable than providing separate renewable energy for each dwelling individually.

1.2: Renewable Energy Technologies

1.2.1 This section gives guidance on the minimum level of renewable technologies to be provided to show compliance with Regulation L2(b). The following represents a reasonable minimum level of energy provision from renewable energy technologies in order to satisfy Regulation L2(b):

- 10 kWh/m²/annum contributing to energy use for domestic hot water heating, space heating or cooling, or
- 4 kWh/m²/annum of electrical energy, or
- a combination of these which would have equivalent effect.

For the purposes of this Section, “renewable energy technologies” means technology, products or equipment that supply energy derived from renewable energy sources, e.g. solar thermal systems, solar photo-voltaic systems, biomass systems, systems using biofuels, heat pumps, aerogenerators and other small scale renewable systems.

1.2.2 Where a building or development contains more than one dwelling, reasonable provision would be to show that:

- every individual dwelling should meet the minimum provision from renewable energy technologies specified in Paragraph 1.2.1 above, or
- the average contribution of renewable technologies to all dwellings in the building or development should meet that minimum level of provision per dwelling.

Where the latter approach is used, common areas in the building are not included in this calculation.

1.2.3 In the case of electrically powered heat pumps, only energy in excess of 2.5 times the electrical energy directly consumed by the heat pump can be counted towards meeting the minimum level of energy provision from renewable technology. In the case of systems based on biofuels or biomass, appliances must be designed to run on these fuels only, i.e. incapable of providing thermal energy from fossil fuels, to be accepted as renewable technology for the purposes of this Regulation. For example a

boiler which could operate on either oil or a biofuel mixture would not be considered to be a renewable technology. Similarly a boiler capable of utilizing coal or peat, in addition to a biomass fuel would not be considered a renewable technology.

1.2.4 The use of centralised renewable energy sources contributing to a heat distribution system serving all dwelling units in a development or part of a development, e.g. an apartment block, may prove to be more practicable than providing separate renewable energy for each dwelling individually.

1.2.5 As an alternative to providing 10kWh/m²/annum thermal energy (or 4 kWh/m²/annum electrical energy) from renewable technology sources, the use of a small-scale combined heat and power (CHP) system which contributes to the space and water heating energy use would be acceptable. This approach may be appropriate in some high density developments, e.g. apartment and mixed use developments.

1.2.6 Part D of the Building Regulations requires that all works be carried out with proper materials and in a workmanlike manner. “Materials” includes products, components and items of equipment and guidance is provided on how products, components and items of equipment can be shown to be “proper materials”. Renewable technologies should satisfy the requirements of Part D in the same way as other construction products and materials. A range of standards applicable to renewable energy technologies are given in the “Standards and Other References” Section in this document. For specific renewable technologies, it is intended that SEI will maintain databases of acceptable products together with information on relevant performance characteristics. Products listed in these databases may be assumed to be “proper materials” for the purposes of this Part of the Building Regulations. It is intended to establish databases for

- Solar thermal systems
- Wood pellet stoves
- Wood pellet/chip boilers
- Heat pumps.

1.2.7 To ensure that works are carried out in a “workmanlike manner”, the design and installation of renewable energy systems to comply with this guidance should be carried out by a person qualified to carry out such work.

1.3: Building Fabric

1.3.1 GENERAL

1.3.1.1 This section gives guidance on acceptable levels of provision to ensure that heat loss through the fabric of a dwelling is limited insofar as reasonably practicable. Guidance is given on three main issues:

- insulation levels to be achieved by the plane fabric elements (Sub-section 1.3.2),
- thermal bridging (Sub-section 1.3.3), and
- limitation of air permeability (Sub-section 1.3.4).

1.3.1.2 Unheated areas which are wholly or largely within the building structure, do not have permanent ventilation openings and are not otherwise subject to excessive air-infiltration or ventilation, e.g. common areas such as stairwells, corridors in buildings containing flats, may be considered as within the insulated fabric. In that case, if the external fabric of these areas is insulated to the same level as that achieved by equivalent adjacent external elements, no particular requirement for insulation between a heated dwelling and unheated areas would arise. It should be noted that heat losses to such unheated areas are taken into account by the DEAP methodology in the calculation of the dwelling EPC and CPC (See Section 1.1).

1.3.2 FABRIC INSULATION

1.3.2.1 The derivation of U-values, including those applicable where heat loss is to an unheated space, is dealt with in Paragraphs 0.3.4 to 0.3.8 and [Appendix A](#).

1.3.2.2 In order to limit heat loss through the building fabric reasonable provision should be made to limit transmission heat loss by plane elements of the building fabric. Acceptable levels of thermal insulation for each of the plane elements of the building to achieve this are specified in terms of average area-weighted U-value (U_m) in [Table 1](#) (Column 2) for each fabric element type. These values can be relaxed for individual elements or parts of elements where considered necessary for design or construction reasons. Maximum acceptable values for such elements or parts of elements are specified in Column 3 of [Table 1](#). Where this relaxation is availed of, the average area-weighted values given in

Column 2 continue to apply and compensatory insulation measures may be necessary for other elements or parts of elements of that type to ensure that these are met. Where the source of space heating is underfloor heating, a floor U-value of 0.15 W/m²K should generally be satisfactory. Further guidance in relation to insulation of floors where underfloor heating is proposed is contained in the document "*Heating and Domestic Hot Water Systems for dwellings – Achieving compliance with Part L*" (to be published).

1.3.2.3 Reasonable provision would also be achieved if the total heat loss through all the opaque elements did not exceed that which would be the case if each of the area-weighted average U-value (U_m) set out in [Table 1](#) were achieved individually. Where this approach is chosen, the values for individual elements or sections of elements given in [Table 1](#), (Column 3) also apply. For ground floors or exposed floors incorporating underfloor heating, the guidance in Paragraph 1.3.2.2 applies.

Table 1 Maximum elemental U value (W/m²K)^{1,2}

Column 1 Fabric Elements	Column 2 Area weighted Average Elemental U- Value (U_m)	Column 3 Average Elemental U-value – individual element or section of element
Roofs		
Pitched roof		
- Insulation at ceiling	0.16	0.3
- Insulation on slope	0.20	
Flat roof	0.22	
Walls	0.27	0.6
Ground Floors ³	0.25	0.6
Other Exposed Floors ³	0.25	0.6
External doors, windows and rooflights	2.00 ⁴	3.0

NOTES

1. The U-value includes the effect of unheated voids or other spaces
2. For alternative method of showing compliance see Paragraph 1.3.2.3
3. For insulation of ground floors and exposed floors incorporating underfloor heating, see Paragraph 1.3.2.2
4. Windows, doors and rooflights should have maximum U-value of 2.0 W/m²K and maximum opening area of 25% of floor area. However areas and U-values may be varied as set out in [Table 2](#)

1.3.2.4 The maximum area-weighted average U-value for doors, windows and rooflights of 2.00 W/m²K given in [Table 1](#) applies when the combined area of external door, window and rooflight openings does not exceed 25% of floor area. However, both the permitted combined area of external door, window and rooflight openings and the maximum area-weighted average U-value of these elements may be varied as set out in [Table 2](#). The area of openings should not be reduced below that required for the provision of adequate daylight. BS 8206: Part 2: 1992 gives advice on adequate daylight provision.

Table 2 Permitted variation in combined areas (A_{ope}) and average U-values (U_{ope}) of external doors, windows and rooflights	
Average U-value of windows, doors and rooflights (U_{ope}) (W/m ² K)	Maximum combined area of external doors, windows and rooflights (A_{ope}), expressed as % of floor area (A_f)
1.0	59.2
1.2	46.5
1.4	38.3
1.6	32.5
1.7	30.2
1.8	28.3
1.9	26.5
2.0	25.0
2.1	22.4
2.2	22.4
2.3	21.3
2.4	20.3
2.6	18.6

NOTE : Intermediate values of “combined areas” or of “U-values” may be estimated by interpolation in the above Table. Alternatively the following expression may be used to calculate the appropriate value:

$$A_{ope}/A_f = 0.4325/(U_{ope} - 0.27).$$

This expression may also be used to calculate appropriate values outside the range covered by the Table.

1.3.2.5 [Diagram 1](#) summarises the minimum fabric insulation standards applicable.

Average Area Weighted Elemental U-values

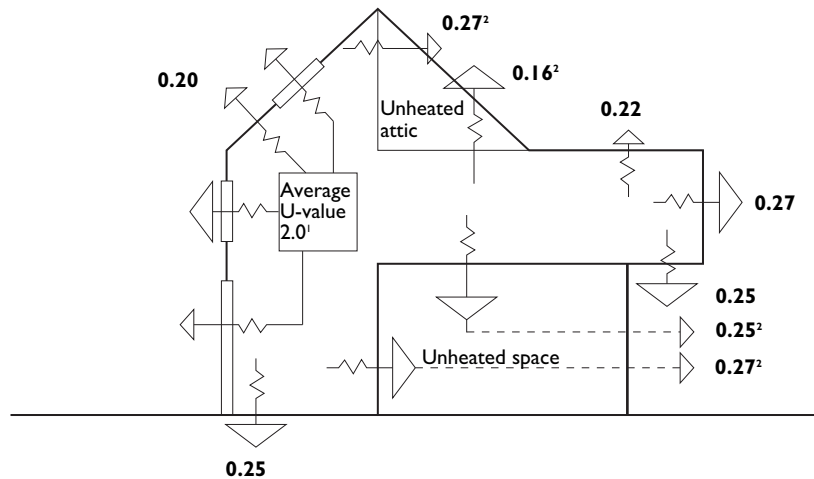

NOTES

1. The average U-value of 2.0 W/m²K for windows, doors and rooflights applies when the area of these elements is equal to 25% of floor area. Average U-value of these elements may vary as set out in Paragraph 1.3.2.4 and Table 2.
2. Average U-values of all elements may vary as set out in Paragraph 1.3.2.3
3. The U-values include the effect of unheated voids and other spaces.

1.3.3 THERMAL BRIDGING

1.3.3.1 To avoid excessive heat losses and local condensation problems, reasonable care should be taken to ensure continuity of insulation and to limit local thermal bridging, e.g. around windows, doors and other wall openings, at junctions between elements and other locations. Any thermal bridge should not pose a risk of surface or interstitial condensation. Heat loss associated with thermal bridges is taken into account in calculating energy use and CO₂ emissions using the DEAP methodology. See [Appendix D](#) for further information in relation to thermal bridging and its effect on dwelling heat loss and how this is taken account of in DEAP calculations.

1.3.3.2 The following represents alternative approaches to making reasonable provision with regard to limitation of thermal bridging:

- (a) Demonstrate by calculation in accordance with the methodology outlined in [Appendix D](#) that all key thermal bridges meet the performance levels set out in [Table D1](#) of [Appendix D](#).
- (b) Adopt details that are similar to, or demonstrated as equivalent to, generic details that have been assessed as limiting thermal bridging to an equivalent level to that set out in [Table D1](#) of [Appendix D](#). A set of such details for typical constructions will be developed in consultation with relevant construction industry organisations and will be made available in a document “*Limiting Thermal Bridging and Air Infiltration – Acceptable Construction Details*” (to be published). Currently, the web document Accredited Details downloadable from the Department of Communities and Local Government (London) website, www.communities.gov.uk contains a significant number of such details. The procedure for assessing the performance of specific details is outlined in [Appendix D](#). It is also expected that further such details will be made available by construction product manufacturers in support of their products.
- (c) Use alternative details which limit the risk of mould growth and surface condensation to an acceptable level as set out in Paragraph D.2 of [Appendix D](#). The documents referred to in (b)

above should not be considered as representing an exhaustive list of acceptable details, and designers and builders may employ well-established details using other materials that are equally suitable.

Irrespective of which approach is used, appropriate provision for on-site inspection and related quality control procedures should be made (See Sub-sections 1.5.2 and 1.5.3).

1.3.3.3 The DEAP calculation of primary energy use and CO₂ emissions (see Section 1.1) takes account of thermal bridging effects. In general this is done by including an allowance for additional heat loss due to thermal bridging, expressed as a multiplier applied to the total exposed surface area. Where provision for thermal bridging is made in accordance with options (a) or (b) of Paragraph 1.3.3.2, this multiplier should be taken as 0.08. Where option (c) of Paragraph 1.3.3.2 is used, it will be necessary to allow for each thermal bridge separately in the calculation. Alternatively a multiplier of 0.15 may be used.

Where details purporting to limit thermal bridging to levels better than the level represented by [Table D1](#) of [Appendix D](#) are used, i.e. a lower loss from thermal bridging is used in the DEAP calculation than that represented by using the 0.08 multiplier, the details used should be fully specified and their performance certified.

1.3.4 BUILDING ENVELOPE AIR PERMEABILITY

1.3.4.1 To avoid excessive heat losses, reasonable care should be taken to limit the air permeability of the envelope of each dwelling. In this context, envelope is the total area of all floors, walls (including windows and doors), and ceilings bordering the dwelling, including elements adjoining other heated or unheated spaces.

1.3.4.2 The following represents a reasonable approach to the design of dwellings to ensure acceptable levels of air permeability:

- (a) Identify the primary air barrier elements (e.g. sheathing, plaster, vapour control layer, breather paper) at early design stage;

- (b) Develop appropriate details and performance specification to ensure continuity of the air barrier and communicate these to all those involved in the construction process;
- (c) Provide on-site inspection regime and related quality control procedures so as to ensure that the design intention is achieved in practice.

1.3.4.3 Achievement of reasonable levels of air permeability can be facilitated by adopting the standard details referred to in Paragraph 1.3.3.2 above, together with an appropriate performance specification and the on-site inspection regime and related quality control procedures, referred to in that paragraph. Alternative approaches to element design, details and quality control procedures may also be acceptable, provided it can be shown that these approaches provide an equivalent level of performance, as if the standard details, performance specification and quality control procedures referred to above were adopted.

1.3.4.4 Air pressure testing should be carried out on a proportion of dwellings on all development sites. See Sub-section 1.5.4 for details of the test procedure, extent of testing, use of test results in DEAP calculations and appropriate measures to be undertaken where the limit set is not achieved. When tested in accordance with the procedure referred to in Sub-section 1.5.4, a performance level of 10m³/(h.m²) represents a reasonable upper limit for air permeability.

1.4: Building Services

1.4.1 GENERAL

1.4.1.1 Regulation L2 (d) requires that space and water heating systems in dwellings be energy efficient, with efficient heat sources and effective controls. More specifically Regulation L2 (e) provides that oil or gas fired boilers must achieve a minimum seasonal net efficiency of 86%. This Section gives guidance for dwellings where the main space and water heating is based on pumped low temperature hot water systems, utilising radiators for space heating and incorporating a hot water cylinder for the storage of domestic hot water, and the fuel used is natural gas, LPG or oil. Guidance is given on three main issues:

- (a) Heating appliance efficiency (Sub-section 1.4.2),
- (b) Space Heating and Hot Water Supply System Controls (Sub-section 1.4.3), and
- (c) Insulation of Hot Water Storage Vessels, Pipes and Ducts (Sub-section 1.4.4)

Detailed guidance for dwellings using a wide range of space and water heating systems is contained in a supporting document “*Heating and Domestic Hot Water Systems for dwellings – Achieving compliance with Part L*” (to be published).

1.4.1.2 This Section also contains guidance in relation to the energy efficiency aspects of mechanical ventilation systems, where provided (Sub-section 1.4.5).

1.4.2 HEATING APPLIANCE EFFICIENCY

1.4.2.1 The appliance or appliances provided to service space heating and hot water systems should be as efficient in use as reasonably practicable. For fully pumped hot water based central heating systems utilizing oil or gas, the boiler seasonal efficiency should be not less than 86% as specified in the DEAP manual and the associated Home-heating Appliance Register of Performance (HARP) database maintained by SEI (www.sei.ie/harp).

1.4.3 SPACE HEATING AND HOT WATER SUPPLY SYSTEM CONTROLS

1.4.3.1 Space and water heating systems should be effectively controlled so as to ensure the efficient use of energy by limiting the provision of heat energy use

to that required to satisfy user requirements, insofar as reasonably practicable. The aim should be to provide the following minimum level of control:

- automatic control of space heating on basis of room temperature;
- automatic control of heat input to stored hot water on basis of stored water temperature;
- separate and independent automatic time control of space heating and hot water;
- shut down of boiler or other heat source when there is no demand for either space or water heating from that source.

The guidance in Paragraphs 1.4.3.2 to 1.4.3.5 below is specifically applicable to fully pumped hot water based central heating systems.

1.4.3.2 Provision should be made to control heat input on the basis of temperature within the heated space, e.g. by the use of room thermostats, thermostatic radiator valves, or other equivalent form of sensing device. For larger dwellings, independent temperature control should generally be provided for separate zones that normally operate at different temperatures, e.g. living and sleeping zones. Thermostats should be located in a position representative of the temperature in the area being controlled and which is not unduly influenced by draughts, direct sunlight or other factors which would directly affect performance. Depending on the design and layout of the dwelling, control on the basis of a single zone will generally be satisfactory for smaller dwellings. For larger dwellings, e.g. where floor area exceeds 100 m², independent temperature control on the basis of two independent zones will generally be appropriate. In certain cases additional zone control may be desirable, e.g. zones which experience significant solar or other energy inputs may be controlled separately from zones not experiencing such inputs.

1.4.3.3 Hot water storage vessels should be fitted with thermostatic control that shuts off the supply of heat when the desired storage temperature is reached.

1.4.3.4 Separate and independent time control for space heating and for heating of stored water should

be provided. Independent time control of space heating zones may be appropriate where independent temperature control applies, but is not generally necessary.

1.4.3.5 The operation of controls should be such that the boiler is switched off when no heat is required for either space or water heating. Systems controlled by thermostatic radiator valves should be fitted with flow control or other equivalent device to ensure boiler switch off.

1.4.4 INSULATION OF HOT WATER STORAGE VESSELS, PIPES AND DUCTS

1.4.4.1 All hot water storage vessels, pipes and ducts associated with the provision of heating and hot water in a dwelling should be insulated to prevent heat loss except for hot water pipes and ducts within the normally heated area of the dwelling that contribute to the heat requirement of the dwelling. Pipes and ducts which are incorporated into wall, floor or roof construction should be insulated.

1.4.4.2 Adequate insulation of hot water storage vessels can be achieved by the use of a storage vessel with factory-applied insulation of such characteristics that, when tested on a 120 litre cylinder complying with I.S. 161: 1975 using the method specified in BS1566, Part 1: 2002, Appendix B, standing heat losses are restricted to 0.8 W/litre. Use of a storage vessel with 50 mm, factory-applied coating of PU-foam having zero ozone depletion potential and a minimum density of 30 kg/m³ satisfies this criterion. Alternative insulation measures giving equivalent performance may also be used.

1.4.4.3 Unless the heat loss from a pipe or duct carrying hot water contributes to the useful heat requirement of a room or space, the pipe or duct should be insulated. The following levels of insulation should suffice:

- (a) pipe or duct insulation meeting the recommendations of BS 5422: 2001 *Methods of specifying thermal insulating materials for pipes, ductwork and equipment (in the temperature range - 400°C to + 700°C)*, or
- (b) insulation with material of such thickness as gives an equivalent reduction in heat loss as that achieved using material having a thermal

conductivity at 400°C of 0.035 W/mK and a thickness equal to the outside diameter of the pipe, for pipes up to 40 mm diameter, and a thickness of 40 mm for larger pipes.

1.4.4.4 The hot pipes connected to hot water storage vessels, including the vent pipe and the primary flow and return to the heat exchanger, where fitted, should be insulated, to the standard outlined in Paragraph 1.4.4.3 above, for at least one metre from their point of connection.

1.4.4.5 It should be noted that water pipes and storage vessels in unheated areas will generally need to be insulated for the purpose of protection against freezing. Guidance on suitable protection measures is given in Report BR 262, *Thermal insulation: avoiding risks* published by BRE.

1.4.5 MECHANICAL VENTILATION SYSTEMS

1.4.5.1 Guidance on good practice with regard to energy efficiency of dwelling ventilation systems is contained in GPG 268 *Energy efficient ventilation in dwellings – a guide for specifiers*, available from SEI.

1.4.5.2 Where a mechanical ventilation system designed for continuous operation (with or without heat recovery) is installed for the provision of ventilation to a dwelling or significant part thereof, the system should meet the performance levels specified in GPG 268 and also have specific fan power and heat recovery efficiency (where appropriate) not worse than those given in Table 3. Significantly better standards in relation to air permeability than those specified in Paragraph 1.3.4.3 are desirable in dwellings with mechanical ventilation, especially ventilation systems with heat recovery. Table 3 does not apply to fans installed for intermittent use in individual rooms.

Table 3 Minimum performance levels for mechanical ventilation systems	
System type	Performance
Specific Fan Power (SFP) for continuous supply only and continuous extract only	0.8 W/litre/sec
SFP for balanced systems	2.0 W/litre/sec
Heat recovery efficiency	66%

1.5: Construction Quality and Commissioning of Services

1.5.1 GENERAL

1.5.1.1 The requirements of Part L apply to the completed building. Reasonable measures should be taken during construction and appropriate checks and assessments carried out prior to completion to ensure that compliance with Part L is achieved. Sub-sections 1.5.2 to 1.5.4 give guidance on appropriate measures to satisfy this requirement.

1.5.2 INSULATION CONTINUITY AND AIR PERMEABILITY

1.5.2.1 The elements that comprise the external fabric of the building should be designed and constructed to ensure that the calculated performance of the building and of its components is achieved in practice. Changes made during design and construction should be assessed for their impact on insulation performance and on air permeability. Those not directly involved in the installation of insulation should be fully aware of the importance of not reducing the effectiveness of the installed insulation through removal or damage. On-site quality control should include checks on the adequacy of insulation installation and of any barriers designed to limit air permeability, including an inspection of finished work to ensure that all work is properly constructed before covering over.

1.5.3 THERMAL BRIDGING

1.5.3.1 There should be no reasonably avoidable thermal bridging, e.g. due to gaps between insulation layers and at joints, junctions and edges around openings. Where unavoidable thermal bridging is provided for in the design, care should be taken to ensure that the chosen design detail is accurately constructed on site.

1.5.4 AIR PERMEABILITY PRESSURE TESTS

1.5.4.1 Air permeability can be measured by means of pressure testing of a building prior to completion. The procedure for testing is specified in IS EN 13829:2000 “*Thermal performance of buildings: determination of air permeability of buildings: fan pressurization method*”. Additional guidance on testing procedure is given in Sections 2 to 4 of the BSRIA Guide “*Airtightness testing for new dwellings*” and

CIBSE Technical Manual TM 23 “*Testing Buildings for Air leakage*”. Permeability is calculated by dividing the air leakage rate in m³/hr by the envelope area in m². The performance is assessed at 50 Pascals pressure difference. It has been empirically determined that for dwellings generally the permeability at 50 Pascals pressure difference is approximately 20 times the air change rate at normal conditions. Guidance on appropriate extent of testing is given in Paragraph 1.5.4.3.

1.5.4.2 Subject to the guidance in Paragraph 1.5.4.7, air pressure testing should be carried out on a proportion of dwellings on all development sites, as outlined in Paragraphs 1.5.4.3 to 1.5.4.6. The tests should be carried out by a person competent to carry out this work. The test report should contain at least the information specified in Section 7 of IS EN 13829.

1.5.4.3 On each development, an air pressure test should be carried out on at least one unit of each dwelling type. One dwelling from the first four units of each dwelling type planned for completion should be tested. The basic number of tests for each dwelling type is presented in [Table 4](#). The total number tested is related to the number of units of that type in the development and to the results achieved in any earlier tests carried out. Where a number of apartment blocks are constructed on the same site, each block should be treated as a separate development irrespective of the number of blocks on the site.

Number of units	Number of tests
4 or less	One test
Greater than 4, but equal or less than 40	Two tests
Greater than 40, but equal or less than 100	At least 5% of the dwelling type
More than 100	(a) where the first five tests achieve the design air permeability (b) where one or more of first five tests do not achieve the design air permeability
	At least 2% (for dwellings in excess of first 100 units) At least 5% of units, until 5 successful consecutive tests are achieved, 2% thereafter

1.5.4.4 If the measured air change rates are not worse than the criterion set out in Paragraph 1.3.4.3, the test results should be taken as satisfactory evidence that the requirements of Part L2 (c), insofar as it relates to air tightness, has been demonstrated for this dwelling type. If satisfactory performance is not achieved in a particular test, then remedial measures should be carried out on the test dwelling and a new test carried out. This should be repeated until the dwelling achieves the criterion set out in Paragraph 1.3.4.3. Dwellings completed later than the most recent successful test on a dwelling of this type should either have similar remedial work carried out or should be subject to pressure test.

1.5.4.5 Where remedial work and a new test is required on any dwelling following initial test, the size of sample for testing should be increased by one, for that dwelling type.

1.5.4.6 Where the air permeability assumed for the DEAP calculations is better than the value derived from pressure test results, a check calculation should be carried out to show that the calculated EPC and CPC using the measured air permeability (after any remedial works to satisfy Paragraph 1.3.4.3, if such are necessary) are not worse than the MPEPC and MPCPC respectively. If necessary, additional remedial works or other measures should be carried out to ensure that this criterion is also met. Where further remedial works to reduce air permeability are undertaken, a further test would be necessary to verify revised air permeability figure to be used in revised DEAP calculations.

1.5.4.7 For small developments comprising no more than three dwelling units, specific pressure testing of these dwellings would not be necessary if it can be demonstrated with air pressure test reports that, during the preceding 12 month period, a dwelling of the same dwelling type constructed by the same builder had been pressure tested according to the procedures given in this sub-section and had satisfied the criterion set in Paragraph 1.3.4.3. However, if the assumed air change rate in the calculation of the EPC and CPC using the DEAP methodology is less than the criterion set in Paragraph 1.3.4.3, a pressure test to verify this assumed value should be carried out. The guidance given in this sub-section would apply in this situation.

1.5.4.8 Air pressurisation test reports should be retained by the developer of the dwelling as proof of performance, and copies included in the User Information referred to in Section 1.6.

1.5.5 COMMISSIONING SPACE AND WATER HEATING SYSTEMS

1.5.5.1 The heating and hot water system(s) should be commissioned so that at completion, the system(s) and their controls are left in the intended working order and can operate efficiently for the purposes of the conservation of fuel and power. The procedure for carrying out commissioning of these systems is set out in *Heating and Domestic Hot Water Systems for Dwellings – Achieving compliance with Part L* (to be published).

1.6: User Information

1.6.1. The owner of the building should be provided with sufficient information about the building, the fixed building services and their maintenance requirements so that the building can be operated in such a manner as to use no more fuel and energy than is reasonable in the circumstances. A way of complying would be to provide a suitable set of operating and maintenance instructions aimed at achieving economy in the use of fuel and energy in a way that householders can understand. The instructions should be directly related to the particular system(s) installed in the dwelling. Without prejudice to the need to comply with health and safety requirements, the instructions should explain to the occupier of the dwelling how to operate the system(s) efficiently. This should include

- (a) the making of adjustments to the timing and temperature control settings, and
- (b) what routine maintenance is needed to enable operating efficiency to be maintained at a reasonable level through the service life(s) of the system(s).

The information to satisfy this requirement may be provided in the context of the Advisory Report to the mandatory Building Energy Rating certificate, augmented as appropriate.

Section 2: Existing Dwellings

2.1: Building Fabric

2.1.1 GENERAL

2.1.1.1 This section gives guidance on acceptable levels of provision to ensure that heat loss through fabric elements provided by way of material alteration or extension to an existing dwelling is limited insofar as reasonably practicable. Guidance is given on three main issues:

- insulation levels to be achieved by the plane fabric elements (Sub-section 2.1.2),
- thermal bridging (Sub-section 2.1.3), and
- limitation of air permeability (Sub-section 2.1.4).

Where a material change of use of an existing building to use as a dwelling occurs, the performance of the fabric elements of the newly provided dwelling should also meet the performance levels specified in this Sub-section.

2.1.1.2 This Part of the Building Regulations applies to the replacement of external doors, windows, or rooflights in an existing building. The average U-value of replacement units should not exceed the value of 2.0 W/m²K set out in Table 5. In this context, the repair or renewal of parts of individual elements, e.g. window glass, window casement sash, door leaf, should be considered as repair and not replacement.

2.1.1.3 Unheated areas which are wholly or largely within the building structure, do not have permanent ventilation openings and are not otherwise subject to excessive air-infiltration or ventilation, e.g. common areas such as stairwells, corridors in buildings containing flats, may be considered as within the insulated fabric. In that case, if the external fabric of these areas is insulated to the same level as that achieved by equivalent adjacent external elements, no particular requirement for insulation between a heated dwelling and unheated areas would arise.

2.1.2 FABRIC INSULATION

2.1.2.1 The derivation of U-values, including those applicable where heat loss is to an unheated space, is dealt with in Paragraphs 0.3.4 to 0.3.8 and [Appendix A](#).

2.1.2.2 Acceptable levels of thermal insulation for each of the plane elements of the building are specified in terms of average area-weighted U-value (U_m) in Table 5 for each fabric element type for extensions (Column 2) and for material alterations and material changes of use (Column 3). These values can be relaxed for individual elements or parts of elements where considered necessary for design or construction reasons. Where this relaxation is availed of, the average area-weighted values given in [Table 5](#) continue to apply and compensatory insulation measures may be necessary for other elements or parts of elements of that type to ensure that these are met. Where the source of space heating is underfloor heating, a floor U-value of 0.15 W/m²K should generally be satisfactory. Further guidance in relation to insulation of floors where underfloor heating is proposed is contained in the document “*Heating and Domestic Hot Water Systems for dwellings – Achieving compliance with Part L*” (to be published).

2.1.2.3 For extensions, reasonable provision would also be achieved if the total heat loss through all the opaque elements did not exceed that which would be the case if each of the area-weighted average U-value (U_m) set out in [Table 5](#) were achieved individually. Where this approach is chosen, the values for individual elements or sections of elements given in [Table 5](#), Column 3 apply to each relevant element. For ground floors or exposed floors incorporating underfloor heating, the guidance in Paragraph 2.1.2.2 applies.

Table 5 Maximum average area-weighted elemental U-value (W/m²K)^{1,2}

Column 1 Fabric Elements	Column 2 Extensions	Column 3 Material Alterations or Material Change of Use
Roofs		
Pitched roof - Insulation at ceiling - Insulation on slope	0.16 0.20	0.35
Flat roof	0.22	
Walls	0.27	0.60
Ground Floors ³	0.25	-
Other Exposed Floors ³	0.25	0.60
External doors, windows and rooflights	2.00 ⁴	2.00 ⁴

NOTES

1. The U-value includes the effect of unheated voids or other spaces
2. For material alterations, the U-values relate to the new works
3. For insulation of ground floors and exposed floors incorporating underfloor heating, see Paragraph 2.1.2.2
4. For extensions and material change of use, windows, doors and rooflights should have maximum U-value of 2.0 W/m²K and maximum opening area of 25% of floor area. However areas and U-values may be varied as set out in Table 6 and Paragraph 2.1.2.4

2.1.2.4 For extensions, the maximum area-weighted average U-value for doors, windows and rooflights of 2.00 W/m²K given in Table 5 applies when the combined area of external door, window and rooflight openings does not exceed 25% of floor area. However, both the permitted combined area of external door, window and rooflight openings and the maximum area-weighted average U-value of these elements may be varied as set out in Table 6. The area of openings should not be reduced below that required for the provision of adequate daylight. BS 8206: Part 2: 1992 gives advice on adequate daylight provision.

2.1.2.5 In applying Paragraph 2.1.2.4 to an extension to an existing dwelling, the relevant floor area may be taken to be:

- (a) the combined floor area of the existing dwelling and extension; in this case the combined area of external doors, windows and rooflight openings refers to the area of such openings in the extended dwelling, i.e. the opening area of retained external doors, windows and rooflights together with the opening area of external doors, windows and rooflights in the extension; or
- (b) the floor area of the extension alone; in this case the combined area of external doors, window and rooflight openings refers to the area of such openings in the extension alone. In this case, the maximum combined area of external doors, windows and rooflights derived using Table 6 can be increased by an area equivalent to the area of external door; window and rooflight openings of the existing dwellings which have been closed or covered over by the extension.

For extensions which

- are thermally separated from the adjacent spaces within the building by walls, doors and other opaque or glazed elements which have U-values not more than 10% greater than corresponding exposed areas of the main dwelling, and
- are unheated or, if provided with a heating facility, have provision for automatic temperature and on-off control independent of the heating provision in the existing building,

the limitation on the combined area of exposed external door, window and rooflight openings does not apply. In this case the average U-value of these elements should not exceed the value of 2.0 W/m²K.

2.1.2.6 This Part of the Building Regulations applies to the replacement of external doors, windows, or rooflights in an existing dwelling. The average U-value of replacement units should not exceed the value of 2.0 W/m²K set out in Table 5. In this context, the repair or renewal of parts of individual elements, e.g. window glass, window casement sash, door leaf should be considered as repair and not replacement.

Table 6 Permitted variation in combined areas (A_{ope}) and average U-values (U_{ope}) of external doors, windows and rooflights	
Average U-value of windows, doors and rooflights (U_{ope}) ($W/m^2 K$)	Maximum combined area of external doors, windows and rooflights (A_{ope}), expressed as % of floor area (A_f)
1.0	59.2
1.2	46.5
1.4	38.3
1.6	32.5
1.7	30.2
1.8	28.3
1.9	26.5
2.0	25.0
2.1	22.4
2.2	22.4
2.3	21.3
2.4	20.3
2.6	18.6

NOTE : Intermediate values of “combined areas” or of “U-values” may be estimated by interpolation in the above Table. Alternatively the following expression may be used to calculate the appropriate value:

$$A_{ope}/A_f = 0.4325/(U_{ope} - 0.27).$$

This expression may also be used to calculate appropriate values outside the range covered by the Table.

2.1.3 THERMAL BRIDGING

2.1.3.1 To avoid excessive heat losses and local condensation problems, reasonable care should be taken to ensure continuity of insulation and to limit local thermal bridging, e.g. around windows, doors and other wall openings, at junctions between elements and other locations. Any thermal bridge should not pose a risk of surface or interstitial condensation. See Appendix D for further information in relation to thermal bridging and its effect on dwelling heat loss.

2.1.3.2 The following represents alternative approaches to making reasonable provision with regard to limitation of thermal bridging

- Demonstrate by calculation in accordance with the methodology outlined in Appendix D that all key thermal bridges meet the

performance levels set out in Table D1 of Appendix D.

- Adopt details that are similar to, or demonstrated as equivalent to, generic details that have been assessed as limiting thermal bridging to an equivalent level to that set out in Table D1 of Appendix D. A set of such details for typical constructions will be developed in consultation with relevant construction industry organisations and will be made available in a document “*Limiting Thermal Bridging and Air Infiltration – Acceptable Construction Details*” (to be published). Currently, the web document Accredited Details downloadable from the Department of Communities and Local Government (London) website www.communities.gov.uk contains a significant number of such details.

2.1.3.3 Lintel, jamb and cill designs similar to those shown in Diagram 2 would be satisfactory and heat losses due to thermal bridging can be ignored if they are adopted. At lintel, jambs and cills generally a 15 mm thickness of insulation material having λ -value of 0.04 W/mK (or equivalent) will generally be adequate.

2.1.3.4 Care should be taken to control the risk of thermal bridging at the edges of floors. All slab-on-ground floors should be provided with edge insulation to the vertical edge of the slab at all external and internal walls. The insulation should have minimum thermal resistance of 0.7 m²K/W (25 mm of insulation with thermal conductivity of 0.035 W/mK, or equivalent). Some large floors may have an acceptable average U-value without the need for added insulation. However, perimeter insulation should always be provided. Perimeter insulation should extend at least 0.5m vertically or 1m horizontally. Where the perimeter insulation is placed horizontally, insulation to the vertical edge of the slab should also be provided as indicated above.

Diagram 2
Lintel, jamb and cill designs

Para 2.1.3.3

LINTELS

JAMBS

CILLS

HEAT LOSS PATHS
 without insulation

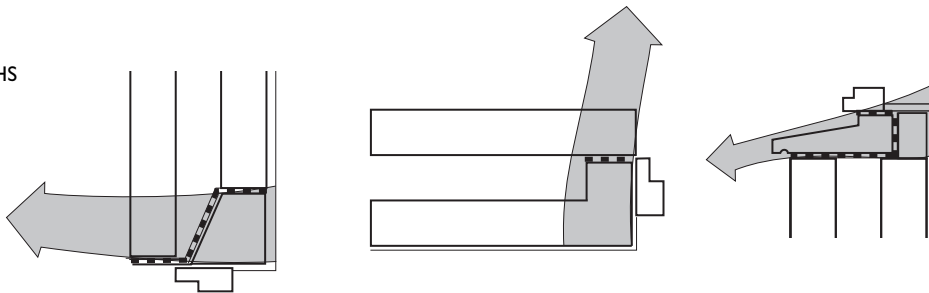

INTERNAL INSULATION

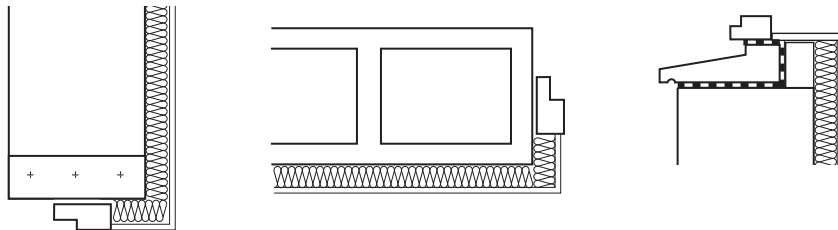

PARTIAL CAVITY FILL

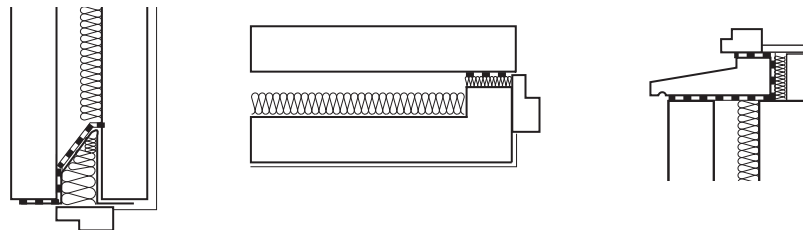

FULL CAVITY FILL

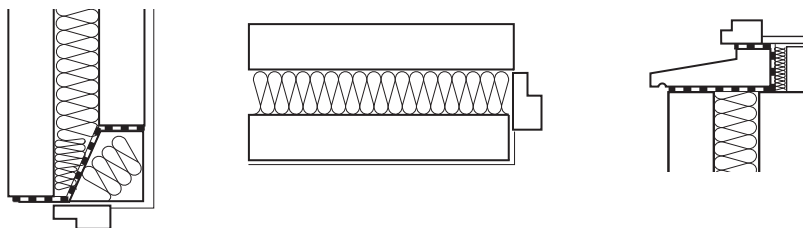

NOTE

- I. The internal faces of metal lintels should be covered with at least 15 mm of lightweight plaster; alternatively they can be dry-lined.

2.1.4 AIR PERMEABILITY

2.1.4.1 Infiltration of cold outside air should be limited by reducing unintentional air paths as far as is practicable. Measures to ensure this include:

- (a) sealing the void between dry-lining and masonry walls at the edges of openings such as windows and doors, and at the junctions with walls, floors and ceilings (e.g. by continuous bands of bonding plaster or battens),
- (b) sealing vapour control membranes in timber-frame constructions,
- (c) fitting draught-stripping in the frames of openable elements of windows, doors and rooflights,

(d) sealing around loft hatches,

- (e) ensuring boxing for concealed services is sealed at floor and ceiling levels and sealing piped services where they penetrate or project into hollow constructions or voids.

Diagram 3 illustrates some of these measures.

Care should be taken to ensure compliance with the ventilation requirements of Part F and Part J.

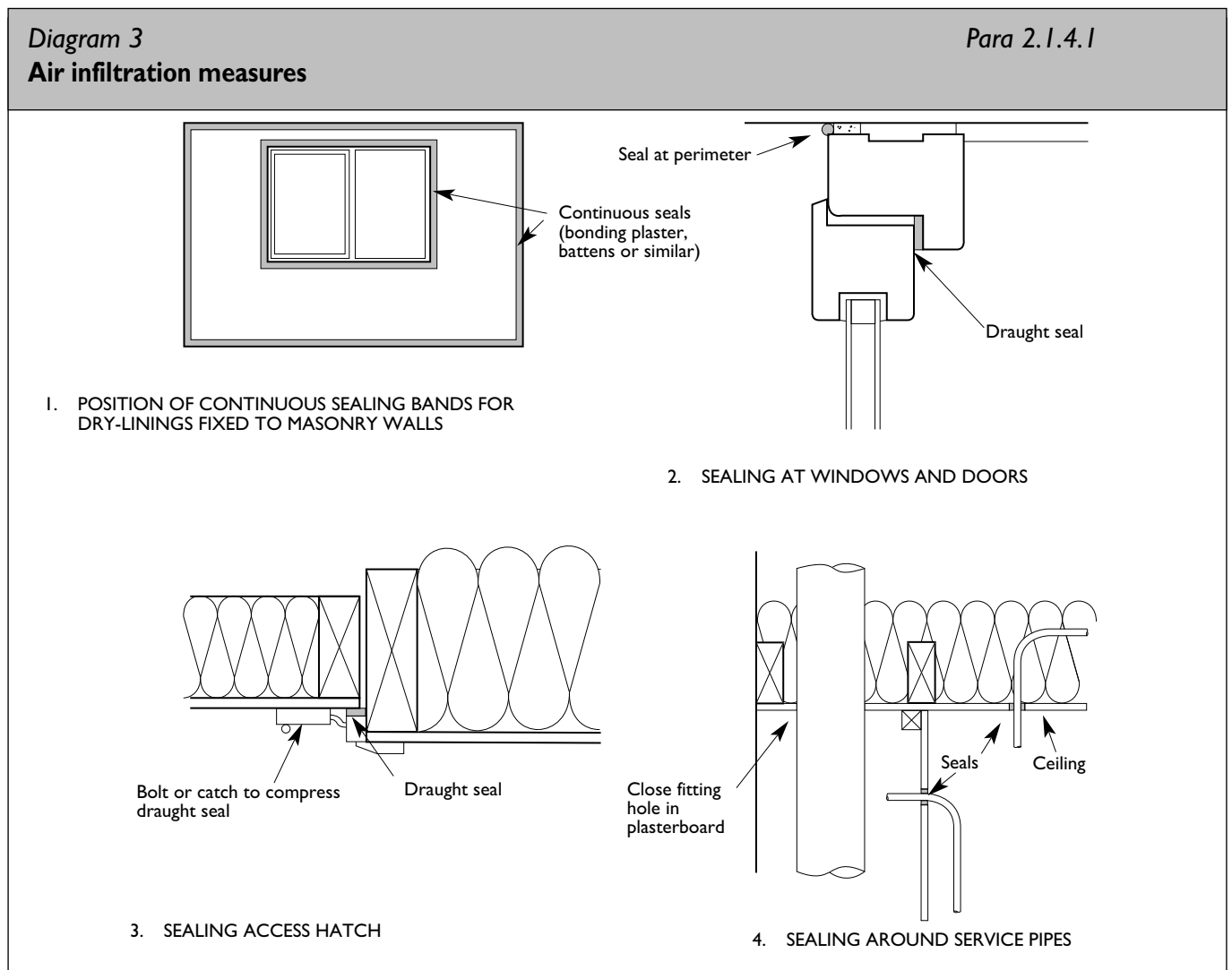

2.2: Building Services

2.2.1 GENERAL

2.2.1.1 Space and water heating systems provided in the context of material alterations to existing dwellings or extensions to existing dwellings should be energy efficient and have efficient heat sources and effective controls. Similar considerations apply to space and water heating systems provided in the context of a material change of use of an existing building to use as a dwelling. Specifically, Regulation L3 provides that oil or gas fired boilers installed as replacements in existing dwellings should have a minimum seasonal net efficiency of 86%, where practicable.

This Section gives guidance where the main space and water heating is based on pumped low temperature hot water systems, utilising radiators for space heating and incorporating a hot water cylinder for the storage of domestic hot water, and the fuel used is natural gas, LPG or oil. Guidance is given on three main issues:

- (a) Heating appliance efficiency (Sub-section 2.2.2),
- (b) Space Heating and Hot Water Supply System Controls (Sub-section 2.2.3), and
- (c) Insulation of Hot Water Storage Vessels, Pipes and Ducts (Sub-section 2.2.4)

Detailed guidance for dwellings using a wide range of space and water heating systems is contained in a supporting document “*Heating and Domestic Hot Water Systems for dwellings – Achieving compliance with Part L*” (to be published).

2.2.2 HEATING APPLIANCE EFFICIENCY

2.2.2.1 The appliance or appliances provided to service space heating and hot water systems should be as efficient in use as reasonably practicable. Guidance on appropriate efficiency for various systems and fuels is contained in “*Heating and Domestic Hot Water Systems for dwellings – Achieving compliance with Part L*” (to be published). For fully pumped hot water based central heating systems utilizing oil or gas, the boiler seasonal efficiency should be not less than 86% as specified in the DEAP

manual and the associated Home-heating Appliance Register of Performance (HARP) database maintained by SEI (www.sei.ie/harp). Effectively this requires the use of condensing boilers. In a limited number of situations involving replacement of existing boilers, provision of a condensing boiler may not be practicable. Detailed guidance on the assessment of specific situations to identify those where provision of condensing boilers is not practicable is given in “*Heating and Domestic Hot Water Systems for dwellings – Achieving compliance with Part L*” (to be published)

2.2.3 SPACE HEATING AND HOT WATER SUPPLY SYSTEM CONTROLS

2.2.3.1 Space and water heating systems should be effectively controlled so as to ensure the efficient use of energy by limiting the provision of heat energy use to that required to satisfy user requirements, insofar as reasonably practicable. The aim should be to provide the following minimum level of control:

- automatic control of space heating on basis of room temperature;
- automatic control of heat input to stored hot water on basis of stored water temperature;
- separate and independent automatic time control of space heating and hot water;
- shut down of boiler or other heat source when there is no demand for either space or water heating from that source.

The guidance in Paragraphs 2.2.3.2 to 2.2.3.5 below is specifically applicable to fully pumped hot water based central heating systems.

2.2.3.2 Provision should be made to control heat input on the basis of temperature within the heated space, e.g. by the use of room thermostats, thermostatic radiator valves, or other equivalent form of sensing device. For larger dwellings, independent temperature control should generally be provided for separate zones that normally operate at different temperatures, e.g. living and sleeping zones. Thermostats should be located in a position representative of the temperature in the area being controlled and which is not unduly

influenced by draughts, direct sunlight or other factors which would directly affect performance. Depending on the design and layout of the dwelling, control on the basis of a single zone will generally be satisfactory for smaller dwellings. For larger dwellings, e.g. where floor area exceeds 100 m², independent temperature control on the basis of two independent zones will generally be appropriate. In certain cases additional zone control may be desirable, e.g. zones which experience significant solar or other energy inputs may be controlled separately from zones not experiencing such inputs.

2.2.3.3 Hot water storage vessels should be fitted with thermostatic control that shuts off the supply of heat when the desired storage temperature is reached.

2.2.3.4 Separate and independent time control for space heating and for heating of stored water should be provided. Independent time control of space heating zones may be appropriate where independent temperature control applies, but is not generally necessary.

2.2.3.5 The operation of controls should be such that the boiler is switched off when no heat is required for either space or water heating. Systems controlled by thermostatic radiator valves should be fitted with flow control or other equivalent device to ensure boiler switch off.

2.2.4 INSULATION OF HOT WATER STORAGE VESSELS, PIPES AND DUCTS

2.2.4.1 Hot water storage vessels, pipes and ducts associated with the provision of space heating and hot water in a dwelling should be insulated to prevent heat loss except for hot water pipes and ducts within the normally heated area of the dwelling that contribute to the heat requirement of the dwelling. Pipes and ducts which are incorporated into wall, floor or roof construction should be insulated.

2.2.4.2 Adequate insulation of hot water storage vessels can be achieved by the use of a storage vessel with factory-applied insulation of such characteristics that, when tested on a 120 litre cylinder complying with I.S. 161: 1975 using the method specified in BS1566, Part 1: 2002, Appendix B, standing heat losses are restricted to 0.8 W/litre. Use of a storage

vessel with 50 mm, factory-applied coating of PU-foam having zero ozone depletion potential and a minimum density of 30 kg/m³ satisfies this criterion. Alternative insulation measures giving equivalent performance may also be used.

2.2.4.3 Unless the heat loss from a pipe or duct carrying hot water contributes to the useful heat requirement of a room or space, the pipe or duct should be insulated. The following levels of insulation should suffice:

- (a) pipe or duct insulation meeting the recommendations of BS 5422: 2001 *Methods of specifying thermal insulating materials for pipes, ductwork and equipment (in the temperature range - 400°C to + 700°C)*, or
- (b) insulation with material of such thickness as gives an equivalent reduction in heat loss as that achieved using material having a thermal conductivity at 400°C of 0.035 W/mK and a thickness equal to the outside diameter of the pipe, for pipes up to 40 mm diameter, and a thickness of 40 mm for larger pipes.

2.2.4.4 The hot pipes connected to hot water storage vessels, including the vent pipe and the primary flow and return to the heat exchanger, where fitted, should be insulated, to the standard outlined in Paragraph 2.2.4.3 above, for at least one metre from their point of connection.

2.2.4.5 It should be noted that water pipes and storage vessels in unheated areas will generally need to be insulated for the purpose of protection against freezing. Guidance on suitable protection measures is given in Report BR 262, *Thermal insulation: avoiding risks* published by BRE.

APPENDICES

Appendix A: Calculation of U-Values

GENERAL

AI.1 General Guidance on the Calculation of U-values is contained in Report BR 443 “Conventions for the Calculation of U-values” 2006. For building elements and components generally, the method of calculating U-values is specified in I.S. EN ISO 6946: 1997. U-values of components involving heat transfer to the ground, e.g. ground floors with or without floor voids, basement walls, are calculated by the method specified in I.S. EN ISO 13370: 1999. A soil thermal conductivity of 2.0 W/mK should be used, unless otherwise verified. U-values for windows, doors and shutters may be calculated using I.S. EN ISO 10077-1: 2000 or I.S. EN ISO 10077-2: 2000. Information on U-values and guidance on calculation procedures contained in the 1999 edition of CIBSE Guide A3: Thermal Properties of Building Structures are based on these standards and may be used to show compliance with this Part.

A method for assessing U-values of light steelframed constructions is given in Digest 465 “U-values for light steel construction”, published by BRE. Guidance in relation to the calculation of U-values for various forms of metal clad construction can be found in Technical Paper No. 14 “Guidance for the design of metal roofing and cladding to comply with Approved Document L2: 2001” published by MCRMA, Technical Information Sheet No. 312, “Metal cladding: U-value calculation assessing thermal performance of built-up metal roof and wall cladding systems using rail and bracket spacers” published by SCI and IP 10/02 “Metal cladding: assessing thermal performance of built-up systems which use ‘Z’ spacers” published by BRE.

AI.2 U-values derived by calculation should be rounded to two significant figures and relevant information on input data should be provided. When calculating U-values the effects of timber joists, structural and other framing, mortar bedding, window frames and other small areas where thermal bridging occurs must be taken into account. Similarly, account must be taken of the effect of small areas where the insulation level is reduced significantly relative to the general level for the component or structure element under consideration. Thermal bridging may be disregarded, however, where the general thermal resistance does not exceed that in the bridged area by more than 0.1 m²K/W. For example, normal mortar joints need not be taken

into account in calculations for brickwork or concrete blockwork where the density of the brick or block material is in excess of 1500 kg/m³. A ventilation opening in a wall or roof (other than a window, rooflight or door opening), may be considered as having the same U-value as the element in which it occurs.

AI.3 Examples of the application of the calculation method specified in I.S. EN 6946: 1997 are given below. An example of the calculation of ground floor U-values using I.S. EN ISO 13370: 1999 is also given.

AI.4 Thermal conductivities of common building materials are given in [Table A1](#) and for common insulating materials in [Table A2](#). For the most part, these are taken from I.S. EN 12524: 2000 or CIBSE Guide A3. See Paragraph 0.3.3 regarding application of these Tables.

SIMPLE STRUCTURE WITHOUT THERMAL BRIDGING

A2.1 To calculate the U-value of a building element (wall or roof) using I.S. EN ISO 6946: 1997, the thermal resistance of each component is calculated, and these thermal resistances, together with surface resistances as appropriate, are then combined to yield the total thermal resistance and U-value. The result is corrected to account for mechanical fixings (e.g. wall ties) or air gaps if required. For an element consisting of homogenous layers with no thermal bridging, the total resistance is simply the sum of individual thermal resistances and surface resistances.

I.S. EN 6946: 1997 provides for corrections to the calculated U-value. In the case of example AI (see [Diagram A1](#)), corrections for air gaps in the insulated layer and for mechanical fasteners may apply. However, if the total correction is less than 3% of the calculated value, the correction may be ignored.

In this case no correction for air gaps applies as it is assumed that the insulation boards meet the dimensional standards set out in I.S. EN ISO 6946: 1997 and that they are installed without gaps greater than 5 mm. The construction involves the use of wall ties that penetrate fully through the insulation layer.

Table A1 Thermal conductivity of some common building materials

Material	Density (kg/m ³)	Thermal Conductivity (W/mK)
General Building Materials		
Clay Brickwork (outer leaf)	1,700	0.77
Clay Brickwork (inner leaf)	1,700	0.56
Concrete block (heavyweight)	2,000	1.33
Concrete block (medium weight)	1,400	0.57
Concrete block (autoclaved aerated)	600	0.18
Concrete block (autoclaved aerated)	350	0.08
Cast concrete, high density	2,400	2.00
Cast concrete, medium density	1,800	1.15
Aerated concrete slab	500	0.16
Concrete screed	1,200	0.41
Reinforced concrete (1% steel)	2,300	2.30
Reinforced concrete (2% steel)	2,400	2.50
Wall ties, stainless steel	7,900	17.00
Wall ties, galvanised steel	7,800	50.00
Mortar (protected)	1,750	0.88
Mortar (exposed)	1,750	0.94
External rendering (cement sand)	1,300	0.57
Plaster (gypsum lightweight)	600	0.18
Plaster (gypsum)	1,200	0.43
Plasterboard	900	0.25
Natural Slate	2,500	2.20
Concrete tiles	2,100	1.50
Clay tiles	2,000	1.00
Fibre cement slates	1,800	0.45
Ceramic tiles	2,300	1.30
Plastic tiles	1,000	0.20
Asphalt	2,100	0.70
Felt bitumen layers	1,100	0.23
Timber, softwood	500	0.13
Timber, hardwood	700	0.18
Wood wool slab	500	0.10
Wood-based panels (plywood, chipboard, etc.)	500	0.13

NOTE: The values in this table are indicative only. Certified values, should be used in preference, if available.

Table A2 Thermal conductivity of some common insulation materials

Material	Density (kg/m ³)	Thermal Conductivity (W/mK)
Insulation		
Expanded polystyrene (EPS) slab (HD)	25	0.035
Expanded polystyrene (EPS) slab (SD)	15	0.038
Extruded polystyrene	30	0.029
Mineral fibre / wool quilt	12	0.044
Mineral fibre / wool batt	25	0.037
Phenolic foam	30	0.025
Polyurethane board (unfaced)	30	0.021

NOTE: The values in this table are indicative only. These may be used for early design purposes. Certified values, taking ageing into account, where appropriate, should be used in final calculations (see para. 0.3.2.)

Example A1: Masonry cavity wall

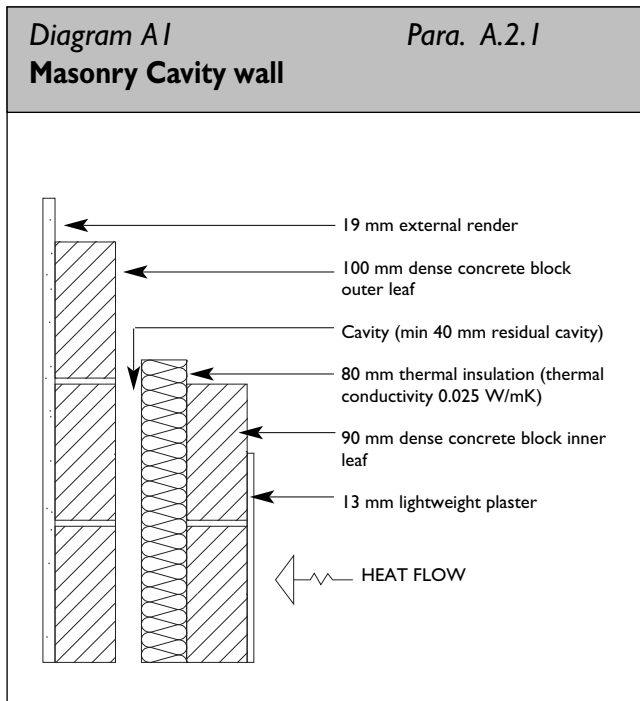

Layer/Surface	Thickness (m)	Conductivity (W/mK)	Resistance (m ² K/W)
External surface	-----	-----	0.040
External render	0.019	0.57	0.033
Concrete Block	0.100	1.33	0.075
Air cavity	-----	-----	0.180
Insulation	0.080	0.025	3.200
Concrete Block	0.100	1.33	0.075
Plaster (lightweight)	0.013	0.18	0.072
Internal surface	-----	-----	0.130
Total Resistance	-----	-----	3.805
U-value of construction = 1/3.805 = 0.26 W/m²K			

A potential correction factor applies which, assuming the use of 4 mm diameter stainless steel ties at 5 ties per m², is calculated as 0.006 W/m²K. This is less than 3% of the calculated U-value and may be ignored. It should be noted that, if galvanised steel wall ties were used, a correction of 0.02 W/m²K would apply, and the corrected U-value for this construction would be 0.28 W/m²K.

STRUCTURE WITH BRIDGED LAYER(S)

A2.2 For an element in which one or more layers are thermally bridged, the total thermal resistance is calculated in three steps as follows.

- (a) The upper thermal resistance is based on the assumption that heat flows through the component in straight lines perpendicular to the element's surfaces. To calculate it, all possible heat flow paths are identified, for each path the resistance of all layers are combined in series to give the total resistance for the path, and the resistances of all paths are then combined in parallel to give the upper resistance of the element.
- (b) The lower thermal resistance is based on the assumption that all planes parallel to the surfaces of the component are isothermal surfaces. To calculate it, the resistances of all components of each thermally bridged layer are combined in parallel to give the effective resistance for the layer, and the resistances of all layers are then combined in series to give the lower resistance of the element.
- (c) The total thermal resistance is the mean of the upper and lower resistances.

Example A2: Timber-frame wall (with one insulating layer bridged)

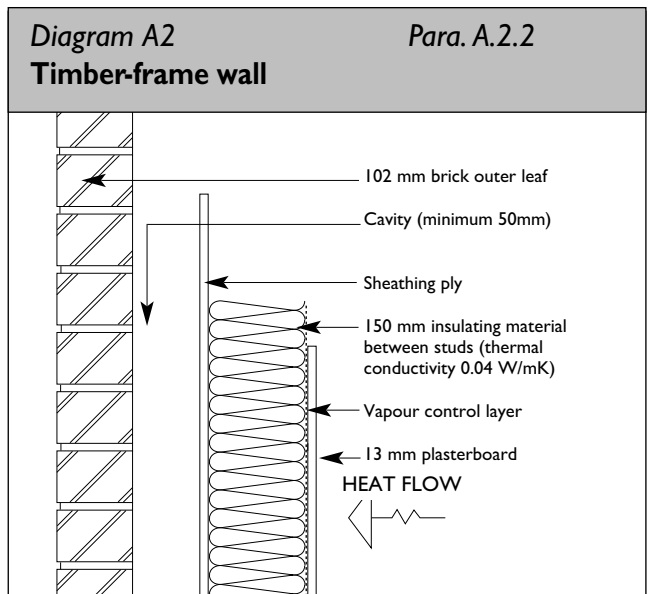

The thermal resistance of each component is calculated (or, in the case of surface resistances, entered) as follows:

Layer/Surface	Thickness (m)	Conductivity (W/mK)	Resistance (m ² K / W)
External surface	---	---	0.040
Brick outer leaf	0.102	0.77	0.132
Air cavity	---	---	0.180
Sheathing ply	0.012	0.13	0.092
Mineral wool insulation	0.150	0.04	3.750
Timber studs	0.150	0.13	1.154
Plasterboard	0.013	0.25	0.052
Internal surface	---	---	0.130

Upper resistance

Assuming that heat flows in straight lines perpendicular to the wall surfaces, there are two heat flow paths - through the insulation and through the studs. The resistance of each of these paths is calculated as follows.

Resistance through section containing insulation [m² K / W]:

External surface resistance	0.040
Brick outer leaf	0.132
Air cavity	0.180
Sheathing ply	0.092
Mineral wool insulation	3.750
Plasterboard	0.052
Internal surface resistance	<u>0.130</u>

Total 4.376

Resistance through section containing timber stud [m² K / W]

External surface resistance	0.040
Brick outer leaf	0.132
Air cavity	0.180
Sheathing ply	0.092
Timber studs	1.154
Plasterboard	0.052
Internal surface resistance	<u>0.130</u>

Total 1.780

The upper thermal resistance R_u is obtained from:

$$R_u = 1 / (F_1 / R_1 + F_2 / R_2)$$

where F_1 and F_2 are the fractional areas of heat flow paths 1 and 2, and R_1 and R_2 are the resistances of these paths.

$$\text{Upper resistance } R_u = 1 / (0.85 / 4.377 + 0.15 / 1.781) = 3.592 \text{ m}^2 \text{ K / W}$$

Lower resistance

Assuming an isothermal plane on each face of the layer of insulation which is bridged by timber studs, the thermal resistance of this bridged layer, R_b , is calculated from

$$R_b = 1 / (F_{ins} / R_{ins} + F_t / R_t)$$

where F_{ins} and F_t are the fractional areas of insulation and timber, and R_{ins} and R_t are their resistances.

$$R_b = 1 / (0.85 / 3.750 + 0.15 / 1.154) = 2.804 \text{ m}^2 \text{ K / W}$$

The resistances of all layers are then combined in series to give the lower resistance [m² K / W]

External surface resistance	0.040
Brick outer leaf	0.132
Air cavity	0.180
Bracing board	0.092
Bridged insulation layer	2.804
Plasterboard	0.052
Internal surface resistance	<u>0.130</u>

Lower resistance (R_l) 3.430

Total resistance

The total resistance R_t is given by:

$$R_t = (R_u + R_l) / 2 = (3.59 + 3.431) / 2 = 3.511 \text{ m}^2 \text{ K / W}$$

The U-value is the reciprocal of the total resistance:

$$U\text{-value} = 1 / 3.511 = 0.28 \text{ W/m}^2\text{K (to 2 decimal places).}$$

There is a potential correction for air gaps in the insulation layer. I.S. EN ISO 6946: 1997 gives a U-value correction of 0.0065 W/m²K for this construction. This is less than 3% of the calculated U-value and can be ignored.

Example A3: Domestic pitched roof with insulation at ceiling level (between and over joists).

A pitched roof has 100 mm of mineral wool tightly fitted between 44 mm by 100 mm timber joists spaced 600 mm apart (centres to centres) and 150 mm of mineral wool over the joists. The roof is slated or tiled with sarking felt under the slates or tiles. The ceiling consists of 13 mm of plasterboard. The fractional area of timber at ceiling level is taken as 8%.

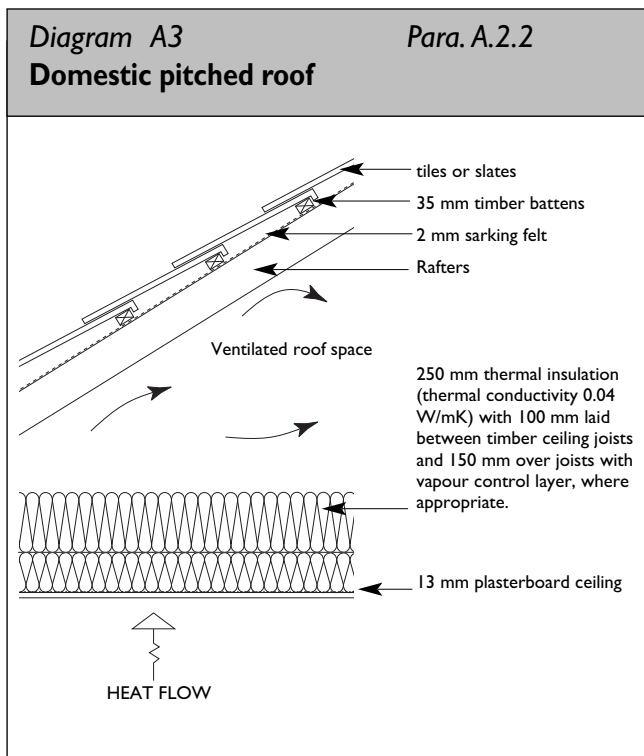

Layer/Surface	Thickness (m)	Conductivity (W/mK)	Resistance (m ² K/W)
External surface	-	-	0.040
Roof space (including sloping construction and roof cavity)	-	-	0.200
Mineral wool (continuous layer)	0.150	0.04	3.750
Mineral wool (between joists)	0.100	0.04	2.500
Timber joists	0.100	0.13	1.154
Plasterboard	0.013	0.25	0.052
Internal surface	-	-	0.100

Upper resistance (R_u)

Resistance through section containing both layers of insulation [m²K/W]

External surface resistance	0.040
Resistance of roof space	0.200
Resistance of mineral wool over joists	3.750
Resistance of mineral wool between joists	2.500
Resistance of plasterboard	0.052
Inside surface resistance	<u>0.100</u>

Total 6.642

Resistance through section containing timber joists

External surface resistance	0.040
Resistance of roof space	0.200
Resistance of mineral wool over joists	3.750
Resistance of timber joists	0.769
Resistance of plasterboard	0.052
Inside surface resistance	<u>0.100</u>

Total 4.911

The upper thermal resistance [R_u] is obtained from:

$$R_u = 1 / (F_1 / R_1 + F_2 / R_2)$$

where F₁ and F₂ are the fractional areas of heat flow paths 1 and 2, and R₁ and R₂ are the resistances of these paths.

$$\text{Upper resistance } R_u = 1 / (0.92 / 6.642 + 0.08 / 4.911) = 6.460 \text{ m}^2 \text{ K/W}$$

Lower resistance (R_l)

Assuming an isothermal plane on each face of the layer of insulation which is bridged by timber studs, the thermal resistance of this bridged layer, R_b, is calculated from

$$R_b = 1 / (F_{ins} / R_{ins} + F_t / R_t)$$

where F_{ins} and F_t are the fractional areas of insulation and timber, and R_{ins} and R_t are their resistances.

$$R_b = 1 / (0.92 / 2.500 + 0.08 / 0.769) = 2.119 \text{ m}^2 \text{ K/W}$$

The resistances of all layers are then combined in series to give the lower resistance [$\text{m}^2\text{K}/\text{W}$]

External surface resistance	0.040
Resistance of roof space	0.200
Resistance of mineral wool over joists	3.750
Resistance of bridged layer	2.119
Resistance of plasterboard	0.052
Inside surface resistance	<u>0.100</u>

Lower resistance (R_l) **6.261**

Total resistance

The total resistance R_t is given by:

$$R_t = (R_u + R_l) / 2 = (6.460 + 6.261) / 2 = 6.361 \text{ m}^2\text{K}/\text{W}$$

The U-value is the reciprocal of the total resistance:

U-value = $1 / 6.361 = 0.16 \text{ W}/\text{m}^2\text{K}$ (to 2 decimal places).

I.S. EN ISO 6946: 1997 does not specify any potential correction for this construction.

GROUND FLOORS AND BASEMENTS

A3.1 The U-value of an uninsulated ground floor depends on a number of factors including floor shape and area and the nature of the soil beneath the floor. I.S. EN ISO 13370: 1999 deals with the calculation of U-values of ground floors. Methods are specified for floors directly on the ground and for floors with vented and unvented sub-floor spaces. I.S. EN ISO 13370: 1999 also covers heat loss from basement floors and walls.

A3.2 In the case of semi-detached or terraced premises, blocks of flats and similar buildings, the floor dimensions can be taken as either those of the individual premises or those of the whole building. Unheated spaces outside the insulated fabric, such as attached porches or garages, should be excluded when deriving floor dimensions but the length of the floor perimeter between the heated building and the unheated space should be included when determining the length of exposed perimeter. Where such ancillary areas have the potential to become part of the habitable area of the dwelling, floors should be insulated to the same level as the dwelling floors unless it is envisaged that a new insulated floor will be provided when converted.

Example A4: Slab-on-ground floor – full floor insulation.

The slab-on-ground floor consists of a 150 mm dense concrete ground floor slab on 100 mm insulation. The insulation has a thermal conductivity of $0.035 \text{ W}/\text{mK}$. The floor dimensions are 8750 mm by 7250 mm with three sides exposed. One 8750 mm side abuts the floor of an adjoining semi-detached house.

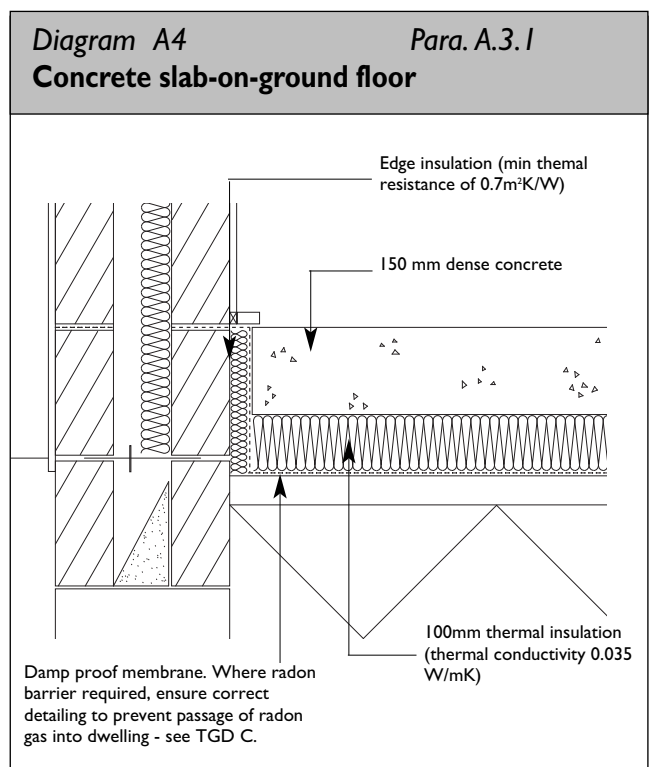

In accordance with I.S. EN ISO 13370: 1999, the following expression gives the U-value for well-insulated floors:

$$\begin{aligned}
 U &= \lambda / (0.457B' + d_t), \text{ where} \\
 \lambda &= \text{thermal conductivity of unfrozen ground (W/mK)} \\
 B' &= 2A/P \text{ (m)} \\
 d_t &= w + \lambda(R_{si} + R_f + R_{se}) \text{ (m)} \\
 A &= \text{floor area (m}^2\text{)} \\
 P &= \text{heat loss perimeter (m)} \\
 w &= \text{wall thickness (m)}
 \end{aligned}$$

R_{si} , R_f and R_{se} are internal surface resistance, floor construction (including insulation) resistance and external surface resistance respectively. Standard values of R_{si} and R_{se} for floors are given as 0.17 m²K/W and 0.04 m²K/W respectively. The standard also states that the thermal resistance of dense concrete slabs and thin floor coverings may be ignored in the calculation and that the thermal conductivity of the ground should be taken as 2.0 W/mK unless otherwise known or specified.

Ignoring the thermal resistance of the dense concrete slab, the thermal resistance of the floor construction (R_f) is equal to the thermal resistance of the insulation alone, i.e. 0.1/0.035 or 2.857 m²K/W. Taking the wall thickness as 300 mm, this gives

$$d_t = 0.30 + 2.0(0.17 + 2.857 + 0.04) = 6.434 \text{ m.}$$

Also $B' = \frac{2(8.75 \times 7.25)}{8.75 + 7.25 + 7.25} = 5.457 \text{ m}$

Therefore $U = \frac{2.0}{(0.457 \times 5.457) + 6.434} = 0.22 \text{ W/m}^2\text{K.}$

The edge insulation to the slab is provided to prevent thermal bridging at the edge of the slab. I.S. EN ISO 13370: 1999 does not consider this edge insulation as contributing to the overall floor insulation and thus reducing the floor U-value. However, edge insulation, which extends below the external ground level, is considered to contribute to a reduction in floor U-value and a method of taking this into account is included in the standard. Foundation walls of insulating lightweight concrete may be taken as edge insulation for this purpose.

ELEMENTS ADJACENT TO UNHEATED SPACES

A4.1 As indicated in Paragraph 0.3.5, the procedure for the calculation of U-values of elements adjacent to unheated spaces (previously referred to as semi-exposed elements) is given in I.S. EN ISO 6946: 1997 and I.S. EN ISO 13789: 2000.

The following formulae may be used to derive elemental U-values (taking the unheated space into account) for typical housing situations irrespective of the precise dimensions of the unheated space.

$$U_o = 1 / (1/U - R_u) \quad \text{or} \quad U = 1 / (1/U_o + R_u)$$

Where: U – U-value of element adjacent to unheated space (W/m²K), taking the effect of the unheated space into account.

U_o – U-value of the element between heated and unheated spaces (W/m²K) calculated as if there was no unheated space adjacent to the element.

R_u – effective thermal resistance of unheated space inclusive of all external elements (m²K / W).

This procedure can be used when the precise details on the structure providing an unheated space are not available, or not crucial.

R_u for typical unheated structures (including garages, access corridors to flats and unheated conservatories) are given in [Tables A3, A4](#) and [A5](#).

[Table A5](#) applies only where a conservatory - style sunroom is not treated as an integral part of the dwelling i.e. is treated as an extension.

In the case of room-in-roof construction, the U-value of the walls of the room-in-roof construction and of the ceiling of the room below the space adjacent to these walls can be calculated using this procedure. See [Diagram A5](#).

Table A3 Typical resistance (R_u) for unheated space.

(a) Integral and adjacent single garages or other similar unheated space.

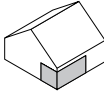
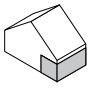
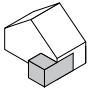
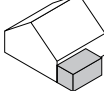
Garage or other similar unheated space	Element between garage and dwelling	R_u
Single fully integral 	Side wall, end wall and floor	0.33
Single fully integral 	One wall and floor	0.25
Single, partially integral displaced forward 	Side wall, end wall and floor	0.26
Single, adjacent 	One wall	0.09

The table gives R_u for single garages; use $(0.5 \times R_u)$ for double garages when extra garage is not fully integral, and $(0.85 \times R_u)$ for fully integral double garages. Single garage means a garage for one car; double garage means a garage for two cars.

Table A4 Typical resistance (R_u) for unheated space

(b) Unheated stairwells and access corridors in flats

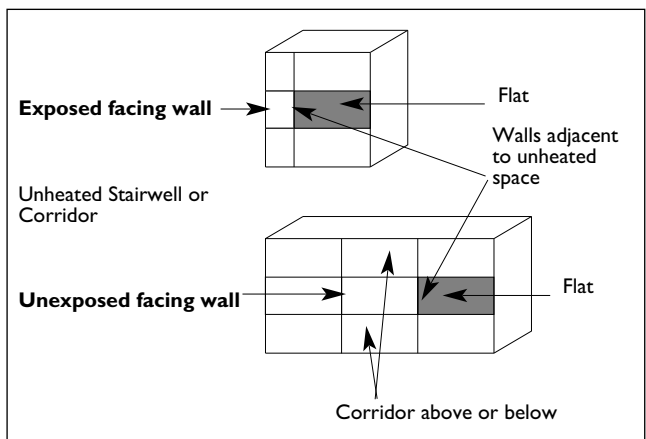

Unheated space	R_u
Stairwells:	
Facing wall exposed	0.82
Facing wall not exposed	0.90
Access corridors:	
Facing wall exposed, corridor above or below	0.31
Facing wall exposed, corridors above and below	0.23
Facing wall not exposed, corridor above or below	0.43

Table A5 Typical resistance (R_u) for unheated space

(c) Conservatory-type sunroom

Number of walls between dwelling and conservatory/sunroom	R_u
One	0.06
Two (conservatory in angle of dwelling)	0.14
Three (conservatory in recess)	0.25

Diagram A5 Room in roof

Para. A.4.1

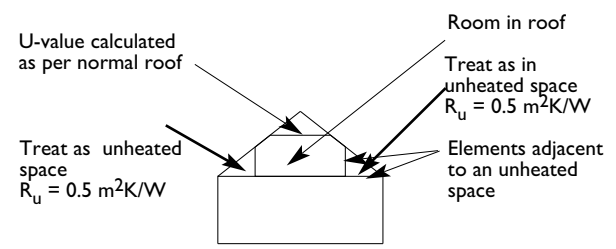

Appendix B: Fabric Insulation: Additional Guidance for Common Construction (- including Tables of U-values)

GENERAL

B.1 This Appendix provides some basic guidance in relation to typical roof, wall and floor constructions. Guidance is not exhaustive and designers and contractors should also have regard to other sources of relevant guidance e.g. BR.262, *Thermal Insulation; avoiding risks*, relevant standards and good building practice.

In particular, diagrams in this Appendix are intended to be illustrative of the construction to which they refer. They do not purport to provide detailed guidance on the avoidance of thermal bridging. See sections 1.3.3 and 2.1.3 for guidance on reasonable provision in this regard.

B.2 For many typical roof, wall and floor constructions, the thickness of insulation required to achieve a particular U-value can be calculated approximately by the use of the appropriate table from this Appendix. The tables can also be used to estimate the U-value achieved by a particular thickness of insulating material. Higher performing insulating materials, i.e. those with lower thermal conductivities, can achieve any given U-value with a lower thickness of insulating material.

B.3 These tables have been derived using the methods described in [Appendix A](#), taking into account the effects of repeated thermal bridging where appropriate. Figures derived from the tables should be corrected to allow for any discrete non-repeating thermal bridging which may exist in the construction. A range of factors are relevant to the determination of U-values and the values given in these tables relate to typical constructions of the type to which the tables refer. The methods described in [Appendix A](#) can be used to calculate a more accurate U-value for a particular construction or the amount of insulation required to achieve a particular U-value.

B.4 Intermediate U-values and values of required thickness of insulation can be obtained from the tables by linear interpolation.

Example B1: Partially filled cavity

What is the U-value of the construction shown in Diagram B1.

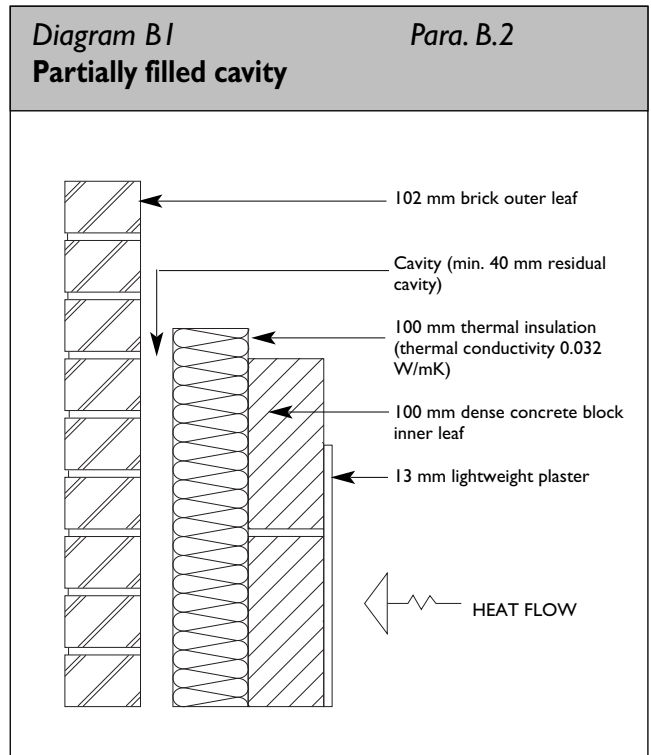

[Table B9](#) gives U-values of 0.29 W/m²K and 0.25 W/m²K for 100 mm insulation of thermal conductivity of 0.035 W/mK and 0.030 W/mK respectively. By linear interpolation, the U-value of this construction, with 100 mm of insulation of thermal conductivity of 0.032 W/mK, is 0.27 W/m²K.

Example B2: Timber frame wall

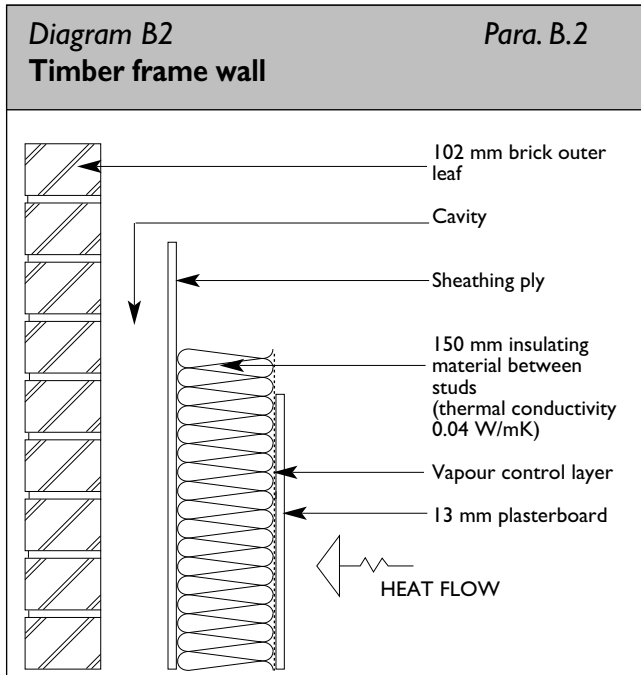

What is the U-value of this construction?
 Table B14 gives the U-value for 150 mm of insulation of thermal conductivity of 0.035 W/mK as 0.27 W/m²K.

Example B3: Pitched roof

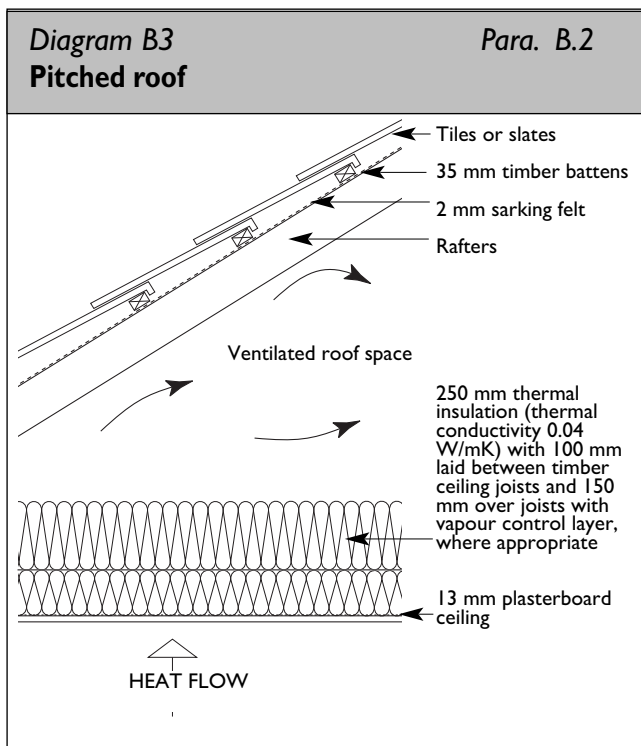

What is the U-value of this construction?
 Table B1 gives the U-value for 250 mm of insulation of thermal conductivity of 0.04 W/mK as 0.16 W/m² K.

ROOF CONSTRUCTIONS

B.5.1 Construction R1: Tiled or slated pitched roof, ventilated roof space, insulation at ceiling level.

B.5.1.1 R1(a) Insulation between and over joists

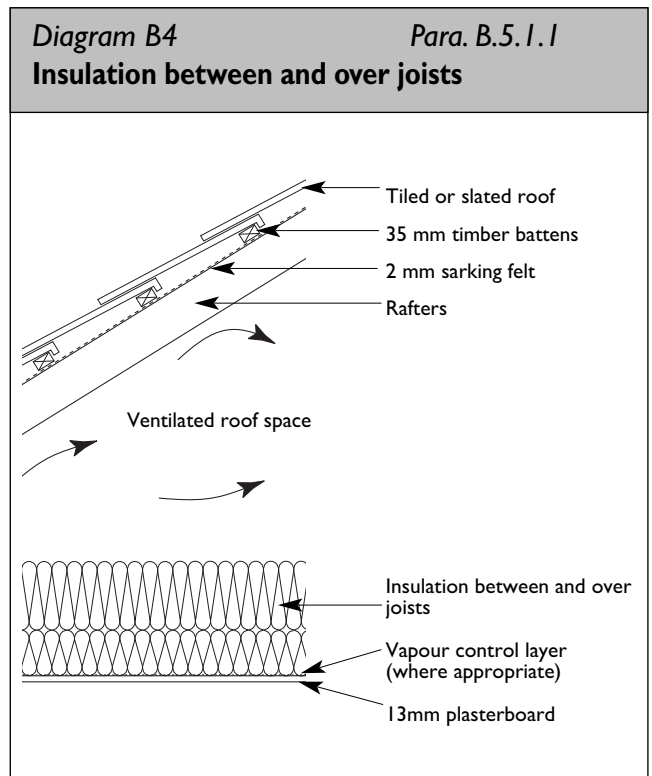

Table B1 U-values for tiled or slated pitched roof, ventilated roof space, insulation placed between and over joists at ceiling level

Total Thickness of insulation (mm)	Thermal conductivity of insulation (W/m K)				
	0.040	0.035	0.030	0.025	0.020
U-Value of construction (W/m ² K)					
150	0.27	0.24	0.21	0.18	0.16
175	0.23	0.20	0.18	0.15	0.13
200	0.20	0.18	0.16	0.13	0.11
225	0.18	0.16	0.14	0.12	0.10
250	0.16	0.14	0.12	0.11	0.09
275	0.14	0.13	0.11	0.10	0.08
300	0.13	0.12	0.10	0.09	0.07

This table is derived for roofs with:

Tiles or slates, felt, ventilated roof space, timber joists ($\lambda = 0.13$) with the spaces between fully filled with insulation and the balance of insulation above and covering joists. (see [Diagram B4](#)). Calculations assume a fractional area of timber thermal bridging of 9%. (includes allowance for loft hatch framing)

Installation guidelines and precautions

Care is required in design and construction, particularly in regard to the following:

Provision of adequate roofspace ventilation

Adequate ventilation is particularly important to ensure the prevention of excessive condensation in cold attic areas. See relevant guidance in TGD F.

Minimising transfer of water vapour from occupied dwelling area to cold attic space

In addition to ensuring adequate ventilation, measures should be taken to limit transfer of water vapour to the cold attic. Care should be taken to seal around all penetrations of pipes, ducts, wiring, etc. through the ceiling, including provision of an effective seal to the attic access hatch. Use of a vapour control layer at ceiling level, on the warm side of the insulation, will assist in limiting vapour transfer, but cannot be relied on as an alternative to ventilation. In particular, a vapour control layer should be used where the roof pitch is less than 15°, or where the shape of the roof is such that there is difficulty in ensuring adequate ventilation, e.g. room-in-the-roof construction.

Minimising the extent of cold bridging.

Particular areas of potential cold bridging include junctions with external walls at eaves and gables, and junctions with solid party walls. Gaps in the insulation should be avoided and the insulation should fit tightly against joists, noggings, bracing etc. Insulation joints should be closely butted and joints in upper and lower layers of insulation should be staggered.

Protecting water tanks and pipework against the risk of freezing.

All pipework on the cold side of the insulation should be adequately insulated. Where the cold water cistern is located in the attic, as is normally the case, the top and sides of the cistern should be insulated. The area underneath the cistern should be left uninsulated and continuity of tank and ceiling insulation should be ensured e.g. by overlapping the tank and ceiling insulation. Provision should be made to ensure ventilation of the tank.

Ensuring that there is no danger from overheating of electric cables or fittings.

Cables should be installed above the insulation. Cables which pass through or are enclosed in insulation should be adequately rated to ensure that they do not overheat. Recessed fittings should have adequate ventilation or other means to prevent overheating.

Providing for access to tanks, services and fittings in the roofspace.

Because the depth of insulation will obscure the location of ceiling joists, provision should be made for access from the access hatch to the cold water tank and to other fittings to which access for occasional maintenance and servicing may be required. This can be done by provision of walkways without compressing the installed insulation.

B.5.1.2 R1(b) Insulation between and below joists.

Insulation is laid in one layer between the joists, protruding above them where its depth is greater, and leaving air gaps above the joists. A composite board of plasterboard with insulation backing is used for the ceiling.

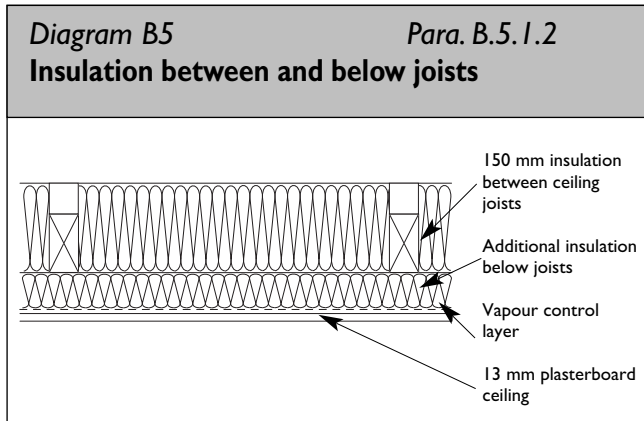

Table B2 U-values for tiled or slated pitched roof, ventilated roof space, insulation placed between and below joists at ceiling level

Total Thickness of insulation (mm)	Thermal conductivity of insulation (W/m K)				
	0.040	0.035	0.030	0.025	0.020
	U-Value of construction (W/m ² K)				
10	0.27	0.27	0.27	0.26	0.26
20	0.26	0.25	0.24	0.24	0.22
30	0.24	0.23	0.22	0.21	0.20
40	0.22	0.22	0.21	0.20	0.18
50	0.21	0.20	0.19	0.18	0.17
60	0.20	0.19	0.18	0.17	0.15
70	0.19	0.18	0.17	0.16	0.14
80	0.18	0.17	0.16	0.15	0.13
90	0.17	0.16	0.15	0.14	0.12
100	0.17	0.16	0.15	0.13	0.12
110	0.16	0.15	0.14	0.13	0.11
120	0.15	0.14	0.13	0.12	0.10

This table is derived for roofs as in [Table B1](#) but with 150 mm of insulation ($\lambda = 0.04$) between ceiling joists, and the remainder below the joists. Insulation of thickness and thermal conductivity as shown in the table is below joists. (See [Diagram B5](#)).

(The insulation thickness shown does not include the thickness of plasterboard in composite boards).

Installation guidelines and precautions.

Similar guidelines and precautions apply as for R1(a) above.

B.5.2 Construction R2: Tiled or slated pitched roof, occupied or unventilated roof space, insulation on roof slope.

B.5.2.1 R2(a) Insulation between and below rafters, 50 mm ventilated cavity between insulation and sarking felt.

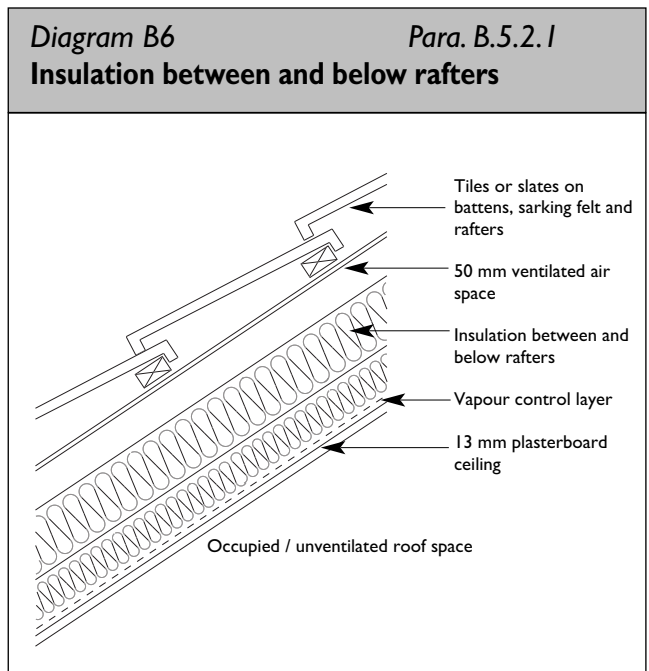

Table B3 U-values for tiled or slated pitched roof, occupied or unventilated roof space, insulation placed between and below rafters

Total Thickness of insulation (mm)	Thermal conductivity of insulation (W/m K)				
	0.040	0.035	0.030	0.025	0.020
U-Value of construction (W/m ² K)					
120	0.34	0.31	0.27	0.24	0.20
140	0.29	0.26	0.23	0.20	0.16
160	0.25	0.23	0.20	0.17	0.14
180	0.22	0.20	0.17	0.15	0.12
200	0.20	0.18	0.16	0.13	0.11
220	0.18	0.16	0.14	0.12	0.10
240	0.17	0.15	0.13	0.11	0.09
260	0.15	0.14	0.12	0.10	0.08

This table is derived for roofs with:

Tiles or slates, felt, rafters of depth 150 mm ($\lambda = 0.13$), 50 mm ventilated air space above insulation, 100 mm insulation between rafters, balance of insulation below and across rafters. (See [Diagram B6](#)).

A fractional area of timber of 8% is assumed. Battens may be fixed to the underside of the rafters to increase rafter depth if necessary.

Installation guidelines and precautions.

The insulation is installed in two layers, one between the rafters (and battens) and the second below and across them. To limit water vapour transfer and minimise condensation risks, a vapour control layer is required on the warm side of the insulation. No material of high vapour resistance, e.g. facing layer attached to insulation to facilitate fixing, should be included within the overall thickness of insulation. Care must be taken to prevent roof timbers and access problems interfering with the continuity of insulation and vapour control layer.

Provision should be made for ventilation top and bottom of the 50 mm ventilation gap on the cold side of the insulation.

An alternative construction using a breathable membrane may be used. In this case the membrane should be certified in accordance with Part D of the Building Regulations and installed in accordance with the guidance on the certificate.

Care should be taken to avoid thermal bridging at roof-wall junctions at eaves, gable walls and party walls.

[Table B3](#) assumes that the thermal conductivity of insulation between and below the rafters is the same. If different insulation materials are used, the material on the warm side (i.e. below rafters) should have a vapour resistance no lower than that on the cold side (i.e. between rafters).

B.5.2.2 R2(b): Insulation above and between rafters, slate or tile underlay of breather membrane type.

Diagram B7 Para. 5.2.2
Insulation above and between rafters

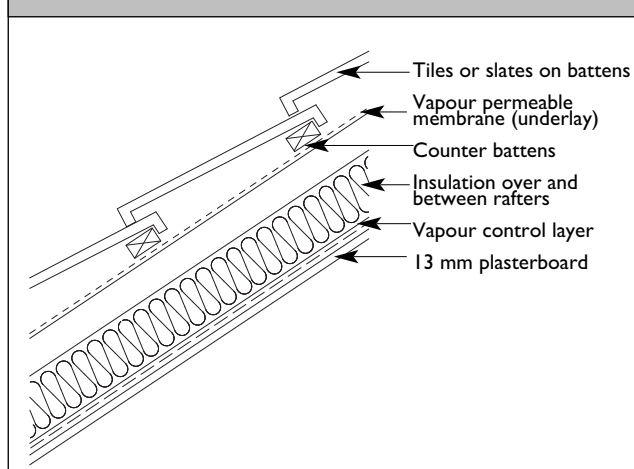

Table B4 U-values for tiled or slated pitched roof, occupied or unventilated roof space, insulation placed between and above rafters.

Total Thickness of insulation (mm)	Thermal conductivity of insulation (W/m K)				
	0.040	0.035	0.030	0.025	0.020
U-Value of construction (W/m ² K)					
120	0.33	0.33	0.27	0.23	0.20
140	0.28	0.25	0.22	0.19	0.16
160	0.25	0.22	0.19	0.17	0.14
180	0.22	0.20	0.17	0.15	0.12
200	0.20	0.18	0.15	0.13	0.11
220	0.18	0.16	0.14	0.12	0.10
240	0.16	0.15	0.13	0.11	0.09
260	0.15	0.13	0.12	0.10	0.08

This table is derived for roofs with:

Tiles or slates, tiling battens, vapour permeable membrane (as underlay), counter battens, insulation layer over rafters, rafters with insulation fitted between. (See [Diagram B7](#)).

Insulation between and over rafters has the same thermal conductivity. A fractional area of timber of 8% is assumed.

Installation guidelines and precautions

The effective performance of this system is critically dependent on the prevention of air and water vapour movement between the warm and cold sides of the insulation. Only systems which are certified or shown by test and calculation as appropriate for this function, (see TGD D, Paragraph 1.1 (a) and (b)) should be used. The precise details of construction are dependent on the insulation and roof underlay materials to be used. Installation should be carried out precisely in accordance with the procedures described in the relevant certificate.

In general, the insulation material must be of low vapour permeability, there should be a tight fit between adjacent insulation boards, and between insulation boards and rafters. All gaps in the insulation (e.g. at eaves, ridge, gable ends, around rooflights and chimneys, etc.) should be sealed with flexible sealant or expanding foam.

Care should be taken to avoid thermal bridging at roof-wall junctions at eaves, gable walls and party walls.

B.5.3 Construction R3: Flat roof, timber joists, insulation below deck

B.5.3.1 R3(a) Insulation between joists, 50 mm air gap between insulation and roof decking

The insulation is laid between the joists. The depth of the joists is increased by means of battens if required.

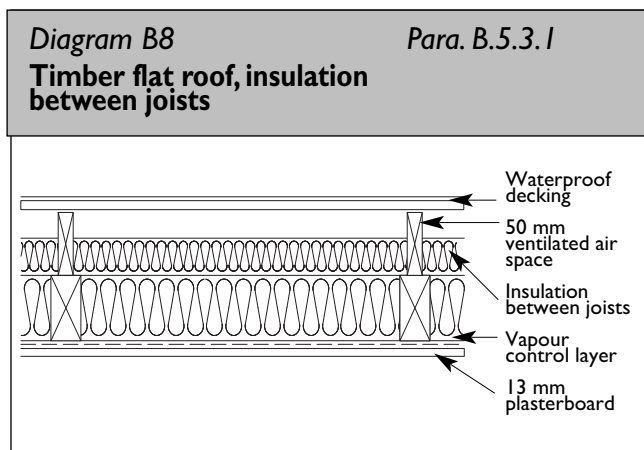

Table B5 U-values for timber flat roof, insulation between joists, 50 mm ventilated air gap between insulation and roof decking.

Total Thickness of insulation (mm)	Thermal conductivity of insulation (W/m K)				
	0.040	0.035	0.030	0.025	0.020
U-Value of construction (W/m ² K)					
150	0.29	0.26	0.24	0.21	0.18
175	0.25	0.23	0.20	0.18	0.16
200	0.22	0.20	0.18	0.16	0.14
225	0.20	0.18	0.16	0.14	0.12
250	0.18	0.16	0.15	0.13	0.11
275	0.16	0.15	0.13	0.12	0.10
300	0.15	0.14	0.12	0.11	0.09

This table is derived for roofs with:
 Weatherproof deck, ventilated air space, insulation as given above between timber joists ($\lambda = 0.13$), 13 mm plasterboard ($\lambda = 0.25$). (See [Diagram B8](#)).
 The calculations assume a fractional area of timber of 8%.

Installation guidelines and precautions

A vapour control layer sealed at all joints, edges and penetrations, is required on the warm side of the insulation, and a ventilated air space as specified in TGD F provided above the insulation. Cross ventilation should be provided to each and every void. When installing the insulation, care is needed to ensure that it does not block the ventilation flow paths.

The integrity of the vapour control layer should be ensured by effective sealing of all service penetrations, e.g. electric wiring, or by provision of a services zone immediately above the ceiling, but below the vapour control layer.

The roof insulation should connect with the wall insulation so as to avoid a cold bridge at this point.

B.5.3.2 R3(b) Insulation between and below joists, 50 mm air gap between insulation and roof decking

The insulation may be installed in two layers, one between the joists as described above, and the second below the joists. This lower layer may be in the form of composite boards of plasterboard backed with insulation, with integral vapour barrier, fixed to the joists. The edges of boards should be sealed with vapour-resistant tape.

Table B6 U-values for timber flat roof, insulation between and below joists, 50 mm ventilated air gap between insulation and roof decking.

Total Thickness of insulation (mm)	Thermal conductivity of insulation (W/m K)				
	0.040	0.035	0.030	0.025	0.020
	U-Value of construction (W/m ² K)				
20	0.34	0.33	0.32	0.31	0.29
40	0.29	0.28	0.27	0.25	0.22
60	0.25	0.24	0.22	0.21	0.18
80	0.22	0.21	0.20	0.18	0.15
100	0.20	0.19	0.17	0.15	0.13
120	0.18	0.17	0.15	0.14	0.12
140	0.17	0.15	0.14	0.12	0.11
160	0.15	0.14	0.13	0.11	0.10

This table is derived for roofs as in [Table B5](#) above, except with 100 mm of insulation ($\lambda = 0.04$) between 150 mm joists, and composite board below joists consisting of 10 mm plasterboard ($\lambda = 0.25$) backed with insulation as specified in this table.

B.5.4 Construction R4: Sandwich warm deck flat roof

The insulation is installed above the roof deck but below the weatherproof membrane. The structural deck may be of timber, concrete or metal.

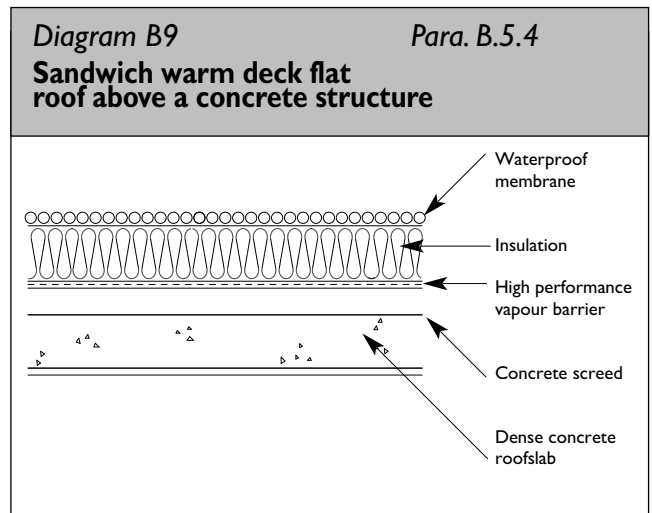

Table B7 U-values for sandwich warm deck flat roof.

Total Thickness of insulation (mm)	Thermal conductivity of insulation (W/m K)				
	0.040	0.035	0.030	0.025	0.020
	U-Value of construction (W/m ² K)				
100	0.34	0.30	0.26	0.22	0.18
125	0.28	0.25	0.22	0.18	0.15
150	0.24	0.21	0.18	0.15	0.13
175	0.21	0.18	0.16	0.13	0.11
200	0.18	0.16	0.14	0.12	0.10
225	0.16	0.14	0.13	0.11	0.09
250	0.15	0.13	0.11	0.10	0.08

This table is derived for roofs with: 12 mm felt bitumen layers ($\lambda = 0.23$), over insulation as given in the table, over 50 mm screed ($\lambda = 0.41$), over 150 mm concrete slab ($\lambda = 2.30$), over 13 mm plasterboard ($\lambda = 0.25$). (See [Diagram B9](#)).

Installation guidelines and precautions

The insulation boards are laid over and normally fully bonded to a high performance vapour barrier complying with BS 747: 2000 which is bonded to the roof deck. The insulation is overlaid with a waterproof membrane, which may consist of a single layer membrane, a fully-bonded built-up bitumen roofing system, or mastic asphalt on an isolating layer. At the perimeter, the vapour barrier is turned up and back over the insulation and bonded to it and the weatherproof membrane. Extreme care is required to ensure that moisture can not penetrate the vapour barrier.

The insulation should not be allowed to get wet during installation.

There should be no insulation below the deck. This could give rise to a risk of condensation on the underside of the vapour barrier.

Thermal bridging at a roof / wall junction should be avoided.

B.5.5 Construction R5: Inverted warm deck flat roof: insulation to falls above both roof deck and weatherproof membrane

Insulation materials should have low water absorption, be frost resistant and should maintain performance in damp conditions over the long term. To balance loss of performance due to the damp conditions and the intermittent cooling effect of water passing through and draining off from the warm side of the insulation, the insulation thickness calculated as necessary for dry conditions should be increased by 20%.

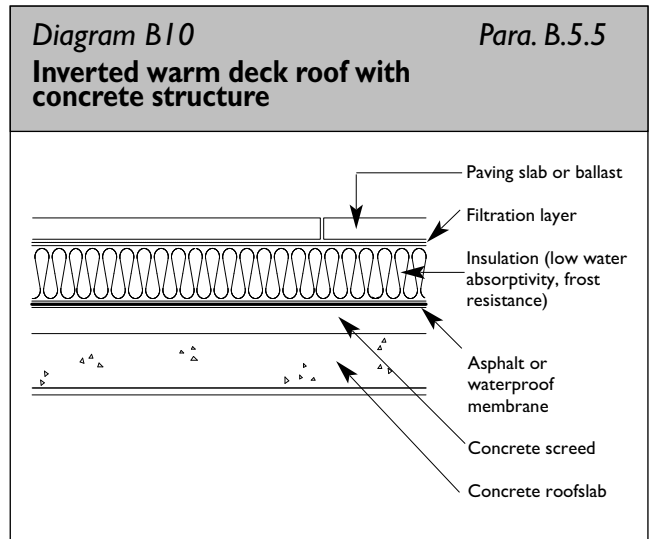

Table B8 U-values for sandwich warm deck flat roof.

Total Thickness of insulation (mm)	Thermal conductivity of insulation (W/m K)				
	0.040	0.035	0.030	0.025	0.020
U-Value of construction (W/m ² K)					
100	0.42	0.39	0.35	0.32	0.28
125	0.37	0.34	0.31	0.28	0.25
150	0.33	0.30	0.28	0.25	0.23
175	0.30	0.28	0.26	0.23	0.21
200	0.28	0.26	0.24	0.22	0.20
225	0.26	0.24	0.23	0.21	0.19
250	0.25	0.23	0.21	0.20	0.18
275	0.24	0.22	0.21	0.19	0.18
300	0.23	0.21	0.20	0.18	0.17

This table is derived for roofs with: 50 mm gravel ballast ($\lambda=2.0$) over 40 mm screed ($\lambda=0.50$) over 40 mm screed ($\lambda=0.41$) over 150 mm concrete ($\lambda=2.30$) over 13 mm plasterboard ($\lambda=0.25$). Insulation thickness derived using correction factor for rain water flow given in I.S. EN 6946. (See Diagram B10).

Installation guidelines and precautions

The insulation is laid on the waterproof membrane. A filtration layer is used to keep out grit, which could eventually damage the weatherproof membrane. The insulation must be restrained to prevent wind uplift and protected against ultraviolet degradation. This is usually achieved by use of gravel ballast, paving stones or equivalent restraint and protection. The insulation should have sufficient compressive strength to withstand the weight of the ballast and any other loads.

Rainwater will penetrate the insulation as far as the waterproof membrane. Drainage should be provided to remove this rainwater. To minimise the effect of rain on performance, insulation boards should be tightly jointed (rebated or tongued-and-grooved edges are preferred), and trimmed to give a close fit around upstands and service penetrations.

To avoid condensation problems, the thermal resistance of the construction between the weatherproof membrane and the heated space is at least 0.15 m²K/W. However, this thermal resistance should not exceed 25% of the thermal resistance of the whole construction.

Thermal bridging at roof / wall junctions should be avoided.

WALL CONSTRUCTIONS

B.6.1. WI: Cavity walls, insulation in cavity, cavity retained (partial fill)

B.6.1.1 WI(a) Brick or rendered dense concrete block external leaf, partial fill insulation, dense concrete block inner leaf, plaster or plasterboard internal finish.

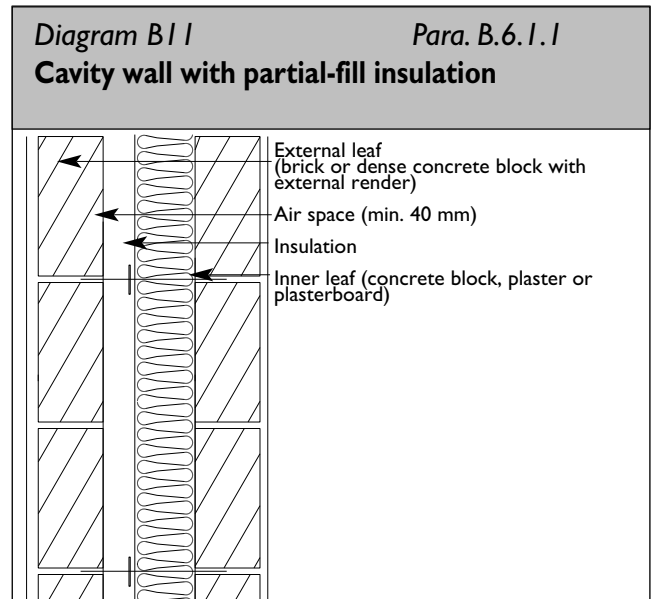

The following tables deal with walls with maximum overall cavity width of 150 mm, which is the greatest cavity width for which details of construction are given in I.S. 325 Part 1: 1986, *Code of Practice for the structural use of concrete; Structural use of unreinforced concrete*. Where it is proposed to use wider cavity widths, full structural and thermal design will be necessary.

Table B9 U-values for brick (or rendered dense concrete block) external leaf, partial fill insulation, dense concrete block inner leaf, plaster (or plasterboard) internal finish.

Total Thickness of insulation (mm)	Thermal conductivity of insulation (W/m K)				
	0.040	0.035	0.030	0.025	0.020
U-Value of construction (W/m ² K)					
60	0.48	0.43	0.39	0.33	0.28
80	0.39	0.35	0.31	0.26	0.22
100	0.32	0.29	0.25	0.22	0.18

This table is derived for walls with:

102 mm clay brickwork outer leaf ($\lambda = 0.77$), 50 mm air space, insulation as specified in table, 100 mm concrete block inner leaf (density = 1800 kg/m³, $\lambda = 1.13$), 13 mm dense plaster ($\lambda = 0.57$). (See [Diagram B11](#)). The effects of wall ties are assumed to be negligible.

The insulation thickness required to achieve a given U-value may be reduced by using lightweight concrete insulating blocks for the inner leaf, as shown in the table below.

Table B10 U-values for construction as Table B9 except for lightweight concrete block inner leaf.

Total Thickness of insulation (mm)	Thermal conductivity of insulation (W/m K)				
	0.040	0.035	0.030	0.025	0.020
U-Value of construction (W/m ² K)					
60	0.40	0.37	0.34	0.30	0.25
80	0.34	0.31	0.27	0.24	0.20
100	0.29	0.26	0.23	0.20	0.17

This table is derived for walls as in Table B9, except heavyweight concrete block inner leaf replaced with 100 mm insulating block ($\lambda = 0.18$).

Calculations assume a 7% fractional area of mortar ($\lambda = 0.88$) bridging the inner leaf.

Note that the sound attenuation performance of lightweight blocks is not as good as that of heavier blocks. This may limit their suitability for use in the inner leaves of attached dwellings.

Installation guidelines and precautions

Insulation should be tight against the inner leaf. Any excess mortar should be cleaned off before fixing insulation. The insulation layer should be continuous and without gaps. Insulation batts should butt tightly against each other. Mortar droppings on batts should be avoided. Batts should be cut and trimmed to fit tightly around openings, cavity trays, lintels, sleeved vents and other components bridging the cavity, and should be adequately supported in position.

Critical locations where care should be taken to limit thermal bridging include lintels, jambs, cills, roof-wall junctions and wall-floor junctions. The method of cavity closure used should not cause thermal bridge at the roof-wall junction.

B.6.1.2 WI(b): As WI(a) except with insulation partly in cavity and partly as internal lining.

If composite boards of plasterboard backed with insulation (of similar conductivity to that used in the cavity) are used internally. Table B9 and B10 can be taken as applying to the total insulation thickness (cavity plus internal). If internal insulation is placed between timber studs, total insulation thickness will be slightly higher due to the bridging effect of the studs. Table B11 applies in this case.

Table B11 U-values for brick (or rendered dense concrete block) external leaf, 60mm partial fill insulation ($\lambda = 0.035$), dense concrete block inner leaf, plasterboard fixed to timber studs, insulation between studs.

Total Thickness of insulation (mm)	Thermal conductivity of insulation (W/m K)				
	0.040	0.035	0.030	0.025	0.020
U-Value of construction (W/m ² K)					
40	0.31	0.31	0.29	0.28	0.26
60	0.28	0.27	0.26	0.24	0.22
80	0.25	0.24	0.23	0.21	0.19
100	0.23	0.22	0.20	0.19	0.17
120	0.21	0.20	0.18	0.17	0.15

This table is derived for walls as in Table B9 above, except with 60 mm of insulation of $\lambda = 0.035$ in cavity, and insulation as specified in the table applied to the internal surface of the wall between timber studs ($\lambda = 0.13$) of fractional area 12%, with a wall finish of 13 mm plasterboard ($\lambda = 0.25$).

Lower U-values, or reduced insulation thickness, can be achieved by using insulating concrete blockwork (rather than dense concrete) between the cavity and internal insulation.

Insulation partly in cavity and partly as internal lining helps minimise thermal bridging. Internal insulation limits thermal bridging at floor and roof junctions, whereas cavity insulation minimises thermal bridging at separating walls and internal fixtures.

Installation guidelines and precautions

Installation of insulation in the cavity should follow the guidelines given above for construction WI(a) (partial-fill cavity insulation), and installation of the

internal lining should follow the guidelines given below for construction W4 (hollow-block).

B.6.2. Construction W2: Cavity walls, insulation in cavity, no residual cavity (full-fill)

The insulation fully fills the cavity. Insulation may be in the form of semi-rigid batts installed as wall construction proceeds, or loose-fill material blown into the cavity after the wall is constructed; the former is considered here. Insulation material suitable for cavity fill should not absorb water by capillary action and should not transmit water from outer to inner leaf. Such insulation may extend below dpc level.

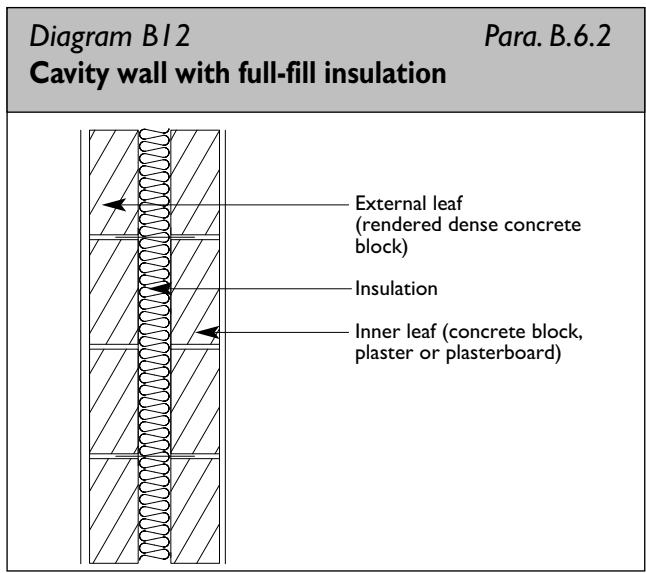

Table B12 U-values for rendered dense concrete block external leaf, full-fill insulation dense concrete block inner leaf, plaster (or plasterboard) internal finish.

Total Thickness of insulation (mm)	Thermal conductivity of insulation (W/m K)				
	0.040	0.035	0.030	0.025	0.020
U-Value of construction (W/m ² K)					
60	0.51	0.46	0.41	0.35	0.29
80	0.41	0.37	0.32	0.27	0.22
100	0.34	0.30	0.26	0.22	0.18
120	0.29	0.26	0.22	0.19	0.16
140	0.25	0.22	0.20	0.17	0.13
160	0.22	0.20	0.17	0.15	0.12

This table is derived for walls with:
 20 mm external rendering ($\lambda = 0.57$), 102 mm clay brickwork outer leaf ($\lambda = 0.77$), insulation as specified in table, 100 mm concrete block inner leaf (medium density - 1800 kg/m^3 , $\lambda = 1.13$), 13 mm dense plaster ($\lambda = 0.57$). The effects of wall ties are assumed to be negligible. (See Diagram B12).

The insulation thickness required to achieve a given U-value may be reduced by using insulating concrete blocks for the inner leaf, as shown in the table below.

Table B13 U-values for rendered dense concrete block external leaf, full-fill insulation, lightweight concrete block inner leaf, plaster (or plasterboard) internal finish.

Total Thickness of insulation (mm)	Thermal conductivity of insulation (W/m K)				
	0.040	0.035	0.030	0.025	0.020
U-Value of construction (W/m ² K)					
60	0.43	0.39	0.35	0.31	0.26
80	0.35	0.32	0.29	0.25	0.21
100	0.30	0.27	0.24	0.21	0.17
120	0.26	0.23	0.21	0.18	0.15
140	0.23	0.21	0.18	0.16	0.13
160	0.21	0.18	0.16	0.14	0.11

This table is derived for walls as above, except heavyweight concrete block inner leaf replaced with 100 mm insulating block ($\lambda = 0.18$).
 Calculations assume a 7% fractional area of mortar ($\lambda = 0.88$) bridging the inner leaf.

Installation guidelines and precautions

Only certified insulation products should be used, and the installation and other requirements specified in such certificates should be fully complied with. In particular, regard should be had to the exposure conditions under which use is certified and any limitations on external finish associated therewith.

Guidance on minimising air gaps and infiltration in partial-fill cavity insulation applies also to full-fill insulation.

Similar issues regarding avoidance of thermal bridging as for construction apply.

B.6.3 Construction W3: Timber frame wall, brick or rendered concrete block external leaf

B.6.3.1 W3(a) Insulation between studs

The insulation is installed between studs, whose depth equals or exceeds the thickness of insulation specified.

In calculating U-values, the fractional area of timber bridging the insulation should be checked. Account should be taken of all timber elements which fully bridge the insulation, including studs, top and bottom rails, noggings, timbers around window and door openings and at junctions with internal partitions, party walls and internal floors. In the table a fractional area of 15% is assumed.

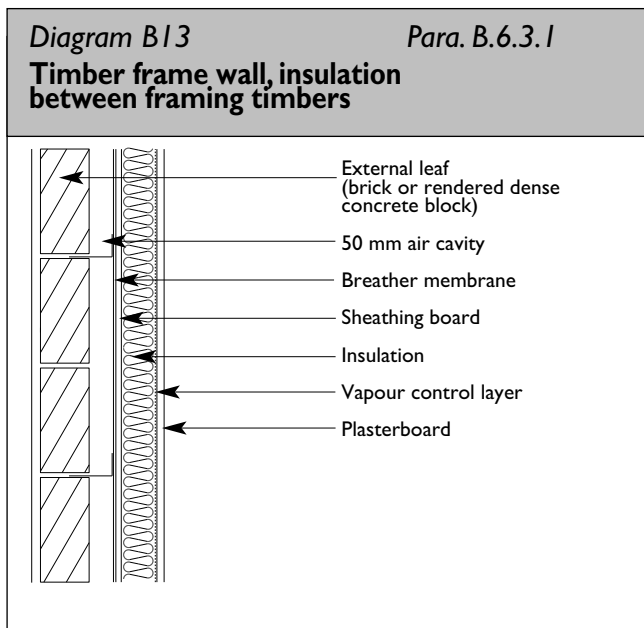

Table B14 U-values for brick (or rendered dense concrete block) external leaf, timber frame inner leaf, insulation between timber studs, plasterboard internal finish.

Total Thickness of insulation (mm)	Thermal conductivity of insulation (W/m K)				
	0.040	0.035	0.030	0.025	0.020
U-Value of construction (W/m ² K)					
100	0.39	0.36	0.34	0.31	0.28
125	0.33	0.31	0.28	0.28	0.23
150	0.29	0.27	0.24	0.24	0.20
175	0.25	0.23	0.21	0.21	0.18

This table is derived for walls with:

102 mm clay brickwork outer leaf ($\lambda = 0.77$), 50 mm air cavity, breather membrane, 12 mm sheathing board ($\lambda = 0.14$), insulation between timber studs ($\lambda = 0.13$), vapour control layer, 13 mm plasterboard ($\lambda = 0.25$). (See [Diagram B13](#)).

The calculations assume a fractional area of timber thermal bridging of 15%.

Installation guidelines and precautions

Air gaps in the insulation layer, and between it and the vapour barrier, should be avoided. Insulation batts should be friction fitted between studs to minimise gaps between insulation and joists. Adjacent insulation pieces should butt tightly together. Particular care is needed to fill gaps between closely-spaced studs at wall/wall and wall/floor junctions, and at corners of external walls.

A vapour control layer should be installed on the warm side of the installation. There should be no layers of high vapour resistance on the cold side of the insulation.

Care is required to minimise thermal bridging of the insulation by timber noggings and other inserts.

B.6.3.2 W3(b): Insulation between and across studs

Where the chosen stud depth is not sufficient to accommodate the required thickness of insulation, insulation can be installed to the full depth between the studs with additional insulation being provided as an internal lining. This additional insulation may be either in the form of plasterboard/insulation composite board or insulation between timber battens, to which the plasterboard is fixed.

Table B15 U-values for brick (or rendered dense concrete block) external leaf, timber frame inner leaf, insulation between 100 mm timber studs, additional insulation, plasterboard internal finish.

Total Thickness of insulation (mm)	Thermal conductivity of insulation (W/m K)				
	0.040	0.035	0.030	0.025	0.020
	U-Value of construction (W/m ² K)				
20	0.32	0.32	0.31	0.29	0.28
40	0.28	0.27	0.25	0.24	0.22
60	0.24	0.23	0.22	0.20	0.18
80	0.22	0.20	0.19	0.17	0.15
100	0.19	0.18	0.17	0.15	0.13

This table is derived for walls as in W3(a) above, except with 100 mm of insulation of $\lambda = 0.04$ between 100mm studs, and an additional layer of insulation as specified in the table across the studs.

The vapour control layer should be on the warm side of the insulation. If different types of insulation are used between and inside the studs, the vapour resistance of the material between the studs should not exceed that of the material across them.

B.6.4 Construction W4: Hollow concrete block wall, rendered externally, internal insulation lining with plasterboard finish.

The insulation is installed on the inner face of the

Diagram B14

Para. B.6.4

Hollow-block wall, internal insulation lining

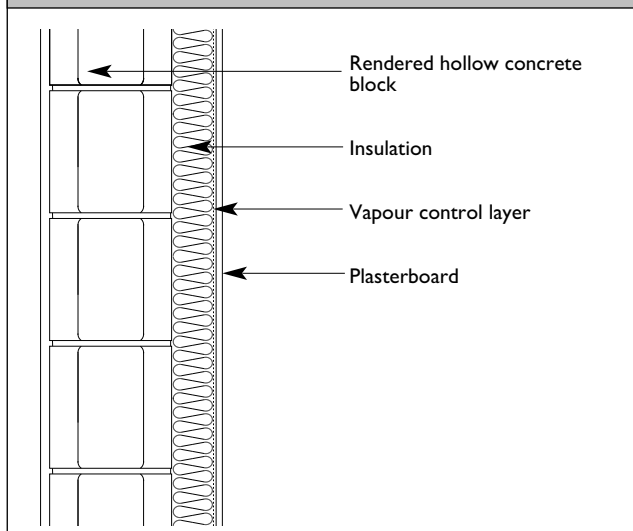

masonry walls. It may be installed between preservative-treated timber studs fixed to the wall, or in the form of composite boards of plaster backed with insulation, or as a combination of these.

Installation guidelines and precautions

Air Movement

Air gaps in the insulation layer should be kept to a minimum. If using insulation between timber studs, there should be no gaps between insulation and studs, between insulation and the vapour control layer, between butt joints in the insulation, around service penetrations, etc. If using composite boards, they should be tightly butted at edges, and should provide complete and continuous coverage of the external wall.

When mounting composite boards on plaster dabs or timber battens, there is a danger that air will be able to circulate behind the insulation, reducing its effectiveness. To minimise such air movement, the air gap behind the boards should be sealed along top and bottom, at corners and around window and door openings e.g. with continuous ribbon of plaster or timber studs.

Table B16 U-values for hollow-block wall, rendered externally, plasterboard fixed to timber studs internally, insulation between studs.

Total Thickness of insulation (mm)	Thermal conductivity of insulation (W/m K)				
	0.040	0.035	0.030	0.025	0.020
U-Value of construction (W/m ² K)					
50	0.67	0.63	0.58	0.53	0.47
75	0.50	0.47	0.43	0.39	0.34
100	0.40	0.37	0.34	0.31	0.27
125	0.34	0.31	0.28	0.25	0.23
150	0.29	0.26	0.24	0.22	0.19
175	0.25	0.23	0.21	0.19	0.17
200	0.22	0.21	0.19	0.17	0.15

Table B17 U-values of hollow-block wall, rendered externally, composite insulation/ plasterboard internally, fixed to timber battens [or plaster dabs]

Total Thickness of insulation (mm)	Thermal conductivity of insulation (W/m K)				
	0.040	0.035	0.030	0.025	0.020
U-Value of construction (W/m ² K)					
40	0.63	0.58	0.52	0.46	0.39
50	0.55	0.50	0.45	0.39	0.32
60	0.48	0.44	0.39	0.34	0.28
70	0.43	0.39	0.34	0.30	0.25
80	0.39	0.35	0.31	0.26	0.22
90	0.35	0.32	0.28	0.24	0.20
100	0.32	0.29	0.26	0.22	0.18
110	0.30	0.27	0.24	0.20	0.16
120	0.28	0.25	0.22	0.19	0.15
130	0.26	0.23	0.20	0.17	0.14
140	0.25	0.22	0.19	0.16	0.13
150	0.23	0.21	0.18	0.15	0.12

These tables are derived for walls with:

19 mm external rendering ($\lambda = 1.00$), 215 mm hollow concrete block (thermal resistance = 0.21 W/m²K), insulation fixed as stated, vapour control layer, 13 mm plasterboard ($\lambda = 0.25$). (See [Diagram B14](#)).

The calculations assume a fractional area of timber thermal bridging of 12% or plaster dab thermal bridging of 20%. as appropriate of 8%.

Condensation

A vapour control layer (e.g. 500 gauge polythene) should be installed on the warm side of the insulation to minimise the risk of interstitial

condensation on the cold masonry behind the insulation. Care should be taken to avoid gaps in the vapour control layer at all joints, edges and service penetrations. The location of service runs in the air gap on the cold side of the insulation should be avoided.

Thermal Bridging

Care should be taken to minimise the impact of thermal bridging. Critical locations have been identified for construction WI. These also apply to this construction.

Other areas where there is a risk of significant thermal bridging include:

Junctions with solid party walls and partitions

Internal partition or party walls of solid dense concrete blockwork can create significant thermal bridge effects at junctions with single leaf masonry external walls.

Junctions with intermediate floors

The external walls in the floor space of intermediate floors should be insulated and protected against vapour movement. Along the wall running parallel to the joists, insulation can be placed between the last joist and the wall. Where the joists are perpendicular to the wall, the insulation and vapour control layer should be continuous through the intermediate floor space and should be carefully cut to fit around the joist ends.

Stairs, cupboards and other fittings supported on or abutting the external wall

Insulation should be carried through behind such fittings.

Ducts, e.g. Soil and vent pipe ducts, against external walls

Insulation should be continuous at all such ducts, i.e. the insulation should be carried through on either the external or internal side of such ducts. Where the insulation is on the external side, particular care should be taken to prevent ingress of cold external air where ducts etc. penetrate the insulation.

FLOOR CONSTRUCTIONS

B.7.1 Construction F1: Ground floor: concrete slab-on-ground. Insulation under slab or under screed

For continuous and uniform insulation under the full ground floor area, the insulation thickness required to achieve prescribed U-values for slab-on-ground floors are given below. These tables apply whether the insulation is located under the slab or under the screed.

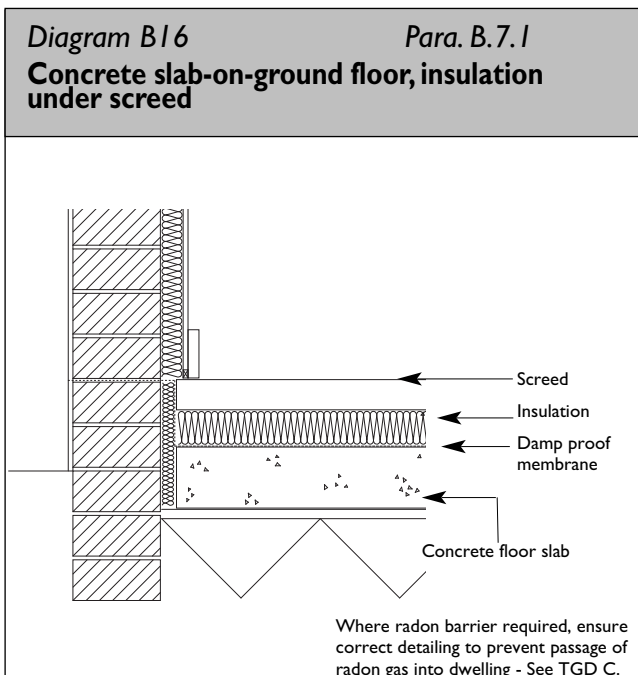
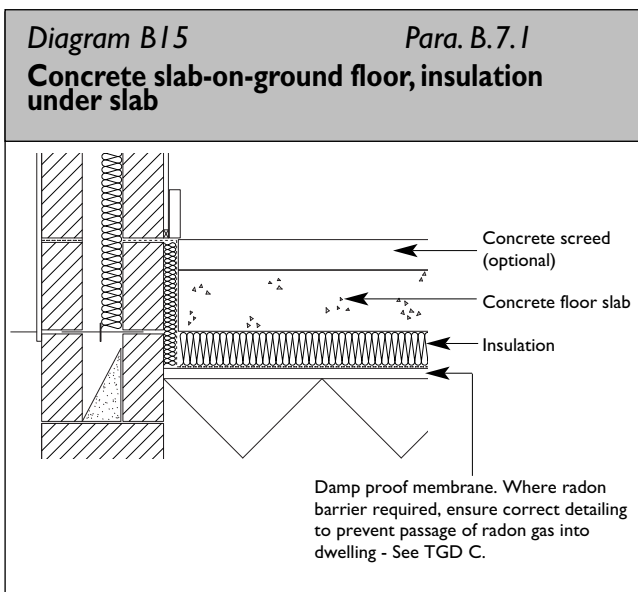

Table B18 allows estimation of the U-value of an insulated floor from the ratio of the length of exposed perimeter to floor area and the thermal resistance of the applied insulation. Table B19 gives the thickness of insulation required to achieve a given U-value when the ratio of exposed perimeter to floor area and the thermal conductivity of the material is known. Both tables are derived for uniform full-floor insulation, ground conductivity of 2.0 W/m²K and full thickness of walls taken to be 0.3m.

Installation guidelines and precautions

The insulation may be placed above or below the dpm/radon barrier. The insulation should not absorb moisture and, where placed below the dpm/radon barrier, should perform well under prolonged damp conditions and should not be degraded by any waterborne contaminants in the soil or fill.

The insulation should have sufficient load-bearing capacity to support the floor and its loading.

The insulation is laid horizontally over the whole area of the floor. Insulation boards should be tightly butted, and cut to fit tightly at edges and around service penetrations.

Table 18: U-value of insulated ground floor as a function of floor area, exposed perimeter and thermal resistance of added insulation (U_{ins}).

Exposed Perimeter/Area (P/A) (m^{-1})	Thermal Resistance of Added Insulation [R_{ins}] (m^2K/W)											
	0.75	1.0	1.25	1.5	1.75	2.0	2.25	2.5	2.75	3.0	3.5	4.0
	1.00	0.66	0.57	0.50	0.44	0.40	0.36	0.33	0.31	0.28	0.27	0.23
0.90	0.64	0.55	0.48	0.43	0.39	0.36	0.33	0.30	0.28	0.26	0.23	0.21
0.80	0.62	0.54	0.47	0.42	0.38	0.35	0.32	0.30	0.28	0.26	0.23	0.21
0.70	0.59	0.52	0.46	0.41	0.37	0.34	0.31	0.29	0.27	0.25	0.23	0.20
0.60	0.57	0.50	0.44	0.40	0.36	0.33	0.31	0.28	0.27	0.25	0.22	0.20
0.50	0.53	0.47	0.42	0.38	0.35	0.32	0.30	0.27	0.26	0.24	0.22	0.19
0.40	0.48	0.43	0.39	0.36	0.33	0.30	0.28	0.26	0.25	0.23	0.21	0.19
0.30	0.43	0.39	0.35	0.32	0.30	0.28	0.26	0.24	0.23	0.22	0.20	0.18
0.20	0.35	0.32	0.30	0.28	0.26	0.24	0.23	0.22	0.21	0.20	0.18	0.16

Table B19 Concrete slab-on-ground floors: Insulation thickness required for U-value of 0.25 W/m^2K .

Total Thickness of insulation (mm)	Thermal conductivity of insulation ($W/m K$)				
	0.040	0.035	0.030	0.025	0.020
	U-Value of construction (W/m^2K)				
0.1	10	8	7	6	5
0.2	64	56	48	40	32
0.3	88	77	66	55	44
0.4	100	88	75	63	50
0.5	110	96	82	69	55
0.6	116	101	87	72	56
0.7	120	105	90	75	60
0.8	123	108	93	77	62
0.9	126	110	94	79	63
1.0	128	112	96	80	64

the areas close to the edge of the floor should be hand trowelled.

Thermal bridging at floor-wall junctions should be minimised.

With cavity walls, thermal bridging via the inner leaf is difficult to avoid, but adequate provision to limit it should be made.

Care should be taken to prevent damage or dislodgement of insulation during floor laying. If the dpm is placed below the insulation, the joints between insulation boards should be taped to prevent wet screed from entering when being poured. If the slab/screed is power-floated, the exposed edges of perimeter insulation should be protected during power-floating, e.g. by boards, or

B.7.2 Construction F2: Ground floor: suspended timber floor, insulation between joists.

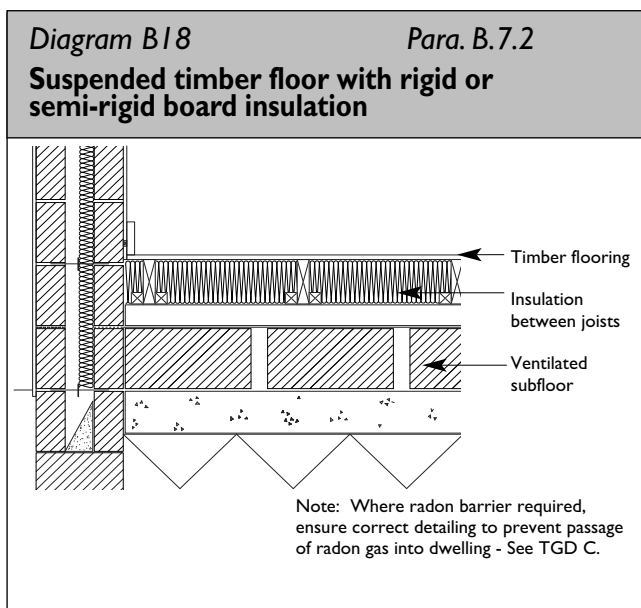
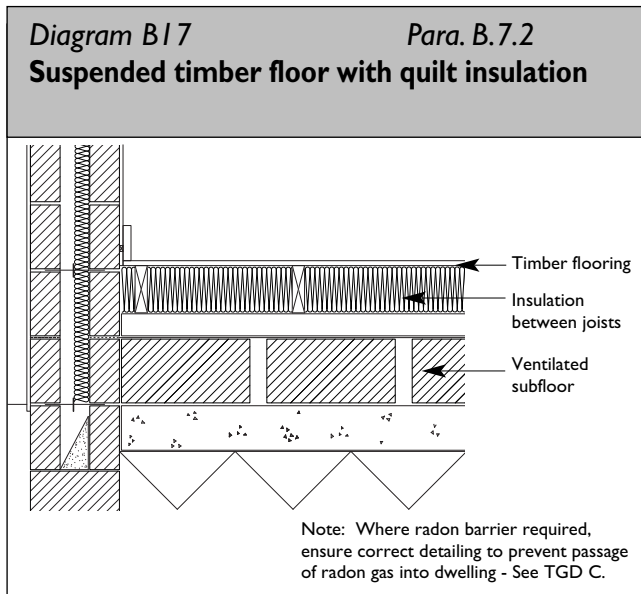

Table B20 Suspended timber ground floors: Insulation thickness required for U-value of 0.25 W/m²K.

Total Thickness of insulation (mm)	Thermal conductivity of insulation (W/m K)				
	0.040	0.035	0.030	0.025	0.020
U-Value of construction (W/m ² K)					
0.1	39	35	31	27	23
0.2	96	87	77	68	58
0.3	117	106	94	83	71
0.4	128	116	103	91	78
0.5	135	122	109	96	82
0.6	139	126	113	99	86
0.7	143	129	116	102	88
0.8	146	132	118	104	89
0.9	148	134	120	105	91
1.0	150	135	121	107	92

This table is derived for:

Suspended floor consisting of 20 mm timber flooring ($\lambda = 0.13$) on timber joists ($\lambda = 0.13$), with insulation between the joists. Ventilated sub-floor space underneath. (See Diagrams B17 and B18).

A fractional area of timber thermal bridging of 11% is assumed.

Installation guidelines and precautions

Where mineral wool quilt insulation is used, the insulation is supported on polypropylene netting or a breather membrane draped over the joists and held against their sides with staples or battens. The full thickness of insulation should extend for the full width between joists. Insulation should not be draped over joists, but cut to fit tightly between them.

Alternatively, rigid or semi-rigid insulation boards, supported on battens nailed to the sides of the joists, may be used.

Thermal bridging, and air circulation around the insulation from the cold vented air space below, should be minimised. The insulation should fit tightly against the joists and the flooring above. Careful placement of supporting battens (or staples) is required to achieve this. At floor-wall junctions the insulation should extend to the walls. The space between the last joist and the wall should be packed with mineral wool to the full depth of the joist. Where internal wall insulation is used, the floor and

wall insulation should meet. Where cavity insulation is used, the floor insulation should be turned down on the internal face and overlap the cavity insulation, or insulating blocks used in the wall at this level.

Cross-ventilation should be provided to the sub-floor space to remove moisture.

Water pipes in the sub-floor space should be insulated to prevent freezing.

B.7.3 Construction F3: Ground floor: suspended concrete floor

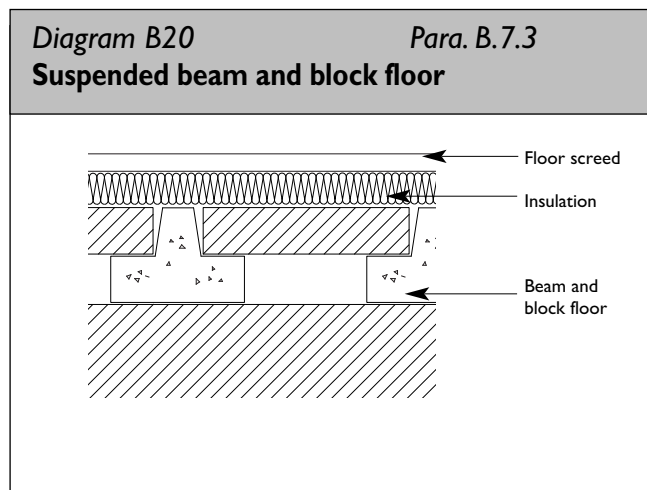
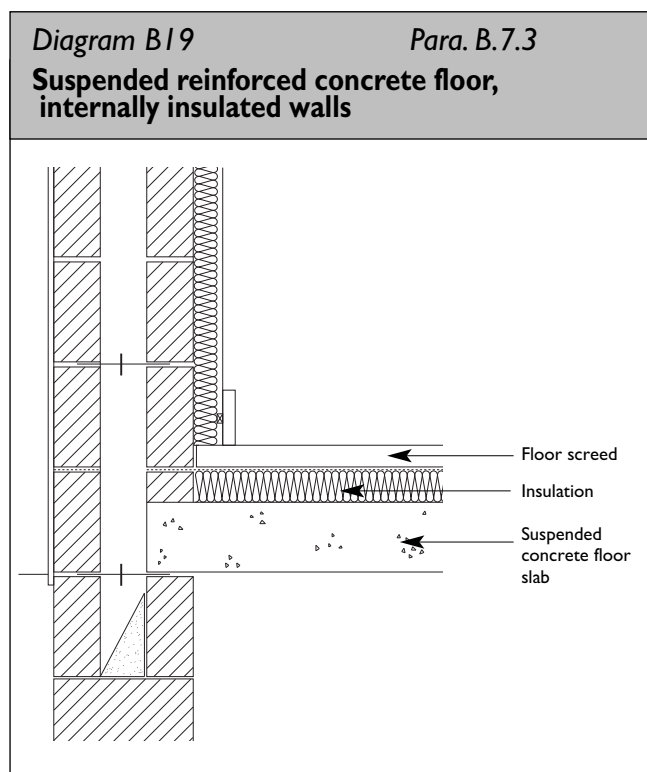

Table B21 Suspended concrete ground floors: Insulation thickness required for U-value of 0.25 W/m²K.

Total Thickness of insulation (mm)	Thermal conductivity of insulation (W/m K)				
	0.040	0.035	0.030	0.025	0.020
U-Value of construction (W/m ² K)					
0.1	19	17	14	12	10
0.2	69	60	52	43	35
0.3	87	76	65	54	44
0.4	96	84	72	60	48
0.5	102	89	77	64	51
0.6	106	93	80	67	53
0.7	109	96	82	69	55
0.8	112	98	84	70	56
0.9	114	99	85	71	57
1.0	115	101	86	72	58

This table is derived for floors with:

65 mm screed ($\lambda = 0.41$) on insulation on 150 mm cast concrete ($\lambda = 2.20$). Full thickness of walls = 0.3 m, U-value of sub-floor walls: 2 W/m²K. Height of floor surface above ground level: 0.3 m. (See Diagrams B19 and B20).

Unventilated sub-floor crawl space underneath.

Installation guidance and precautions

If the walls are internally insulated, it is recommended that the floor insulation be placed above the floor structure, since it can then connect with the wall insulation. Thermal bridging at the floor-wall junction is difficult to avoid when insulation is placed below the floor structure.

If the walls are cavity insulated, floor insulation can not connect with wall insulation, so some thermal bridging is inevitable. It can be minimised by using insulating blocks for the inner leaf between overlapping floor and wall insulation. Insulation and insulating blocks may be either above or below the floor structure, but above is recommended. This will allow the use of less dense blocks (of lower thermal conductivity), since they will not have to support the weight of the floor. Also, above the structure they will be above the dpc, where their lower moisture content will give a lower thermal conductivity than below the dpc. Heat loss from the floor can be further reduced by extending the cavity insulation down to, or below, the lower edge of the suspended floor.

B.7.4 Construction F4: Exposed floor: timber joists, insulation between joists

Diagram B21 Para. B.7.4
Exposed timber floor, insulation between joists

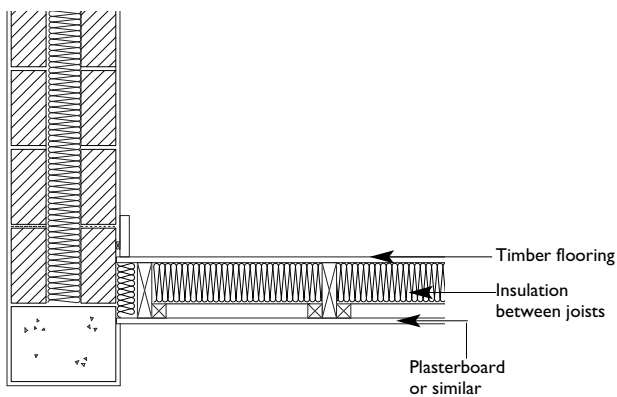

Table B22 U-values for exposed timber floors, insulation between timber joists, plasterboard finish.

Total Thickness of insulation (mm)	Thermal conductivity of insulation (W/m K)				
	0.040	0.035	0.030	0.025	0.020
	U-Value of construction (W/m ² K)				
100	0.41	0.37	0.34	0.31	0.27
120	0.35	0.32	0.29	0.26	0.23
140	0.31	0.28	0.25	0.23	0.20
160	0.27	0.25	0.23	0.20	0.18
180	0.25	0.22	0.20	0.18	0.16
200	0.22	0.20	0.19	0.17	0.15

This table is derived for floors with:

20 mm timber flooring ($\lambda = 0.13$), insulation as specified in table between timber joists ($\lambda = 0.13$) of equal depth, 13 mm plasterboard ($\lambda = 0.25$). The calculations assume a fractional area of timber thermal bridging of 11%. (See [Diagram B21](#))

Installation guidance and precautions

The flooring on the warm side of the insulation should have a higher vapour resistance than the outer board on the cold side. If necessary, a vapour check should be laid across the warm side of the insulation. Methods of avoiding thermal bridging at junctions with internally insulated and cavity insulated walls are similar to those described for suspended timber ground floors above.

B.7.5 Construction F5: Exposed floor: solid concrete, insulation external

insulation around the edge beam to connect with the cavity insulation as shown in [Diagram B22](#).

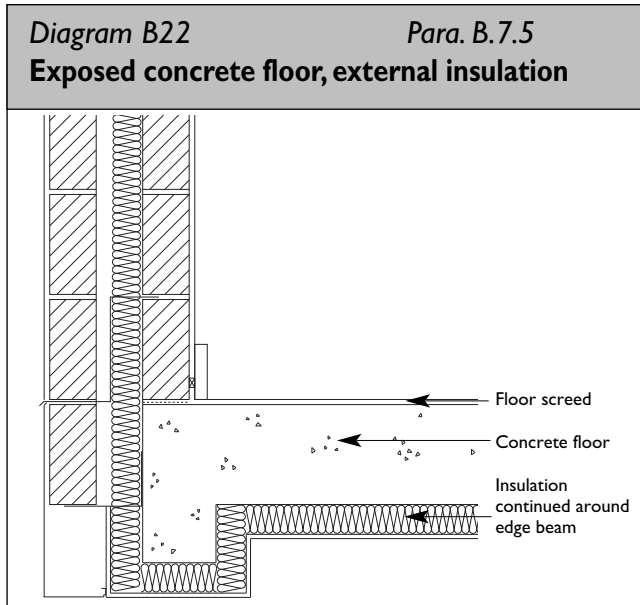

Table B23 U-values for exposed concrete floors, external insulation, external render

Total Thickness of insulation (mm)	Thermal conductivity of insulation (W/m K)				
	0.040	0.035	0.030	0.025	0.020
U-Value of construction (W/m ² K)					
60	0.54	0.48	0.42	0.36	0.30
80	0.42	0.38	0.33	0.28	0.23
100	0.35	0.31	0.27	0.23	0.19
120	0.30	0.26	0.23	0.19	0.16
140	0.26	0.23	0.20	0.17	0.14
160	0.23	0.20	0.18	0.15	0.12

This table is derived for floors with:

150 mm cast concrete ($\lambda = 1.35$), insulation, 20 mm external render. (See [Diagram B22](#)).

Installation guidance and precautions

If the walls are internally insulated, this floor construction is not recommended. Floor insulation should instead be located internally in order to connect with the wall insulation.

With cavity wall insulation, thermal bridging may be minimised by supporting the external leaf independently, and continuing the external floor

Table B24: Indicative U-values (W/m²K) for windows, doors and roof windows

The values apply to the entire area of the window opening, including both frame and glass, and take account of the proportion of the area occupied by the frame and the heat conducted through it. If the U-value of the components of the window (glazed unit and frame) are known, window U-values may alternatively be taken from the tables in Annex F of I.S. EN ISO 10077-1, using the tables for 20% frame for metal-framed windows and those for 30% frame for wood or PVC-U framed windows.

When available, the manufacturer's certified U-values for windows or doors should be used in preference to the data in this table. Adjustments for roof windows should be applied to manufacturer's window U-values unless the manufacturer provides a U-value specifically for a roof window.

Table B24 Indicative U-values (W/m ² K) for windows, doors and rooflights						
	Type of frame					
	Window with wood or PVC-U frame (use adjustment in Note 1)			Window with metal frame with 4mm thermal break (use adjustments in Note 2)		
	6 mm gap	12 mm gap	16 or more mm gap	6 mm gap	12 mm gap	16 or more mm gap
double-glazed, air filled	3.1	2.8	2.7	3.7	3.4	3.3
double-glazed, air filled (low-E, $\hat{A}_n = 0.2$, hard coat)	2.7	2.3	2.1	3.3	2.8	2.6
double-glazed, air filled (low-E, $\hat{A}_n = 0.15$, hard coat)	2.7	2.2	2.0	3.3	2.7	2.5
double-glazed, air filled (low-E, $\hat{A}_n = 0.1$, soft coat)	2.6	2.1	1.9	3.2	2.6	2.4
double-glazed, air filled (low-E, $\hat{A}_n = 0.05$, soft coat)	2.6	2.0	1.8	3.2	2.5	2.3
double-glazed, argon filled	2.9	2.7	2.6	3.5	3.3	3.2
double-glazed, argon filled (low-E, $\hat{A}_n = 0.2$, hard coat)	2.5	2.1	2.0	3.0	2.6	2.5
double-glazed, argon filled (low-E, $\hat{A}_n = 0.15$, hard coat)	2.4	2.0	1.9	3.0	2.5	2.4
double-glazed, argon filled (low-E, $\hat{A}_n = 0.1$, soft coat)	2.3	1.9	1.8	2.9	2.4	2.3
double-glazed, argon filled (low-E, $\hat{A}_n = 0.05$, soft coat)	2.3	1.8	1.7	2.8	2.2	2.1
triple glazed, air filled	2.4	2.1	2.0	2.9	2.6	2.5
triple-glazed, air filled (low-E, $\hat{A}_n = 0.2$, hard coat)	2.1	1.7	1.6	2.6	2.1	2.0
triple-glazed, air filled (low-E, $\hat{A}_n = 0.15$, hard coat)	2.1	1.7	1.6	2.5	2.1	2.0
triple-glazed, air filled (low-E, $\hat{A}_n = 0.1$, soft coat)	2.0	1.6	1.5	2.5	2.0	1.9
triple-glazed, air filled (low-E, $\hat{A}_n = 0.05$, soft coat)	1.9	1.5	1.4	2.4	1.9	1.8
triple-glazed, argon filled	2.2	2.0	1.9	2.8	2.5	2.4
triple-glazed, argon filled (low-E, $\hat{A}_n = 0.2$, hard coat)	1.9	1.6	1.5	2.3	2.0	1.9
triple-glazed, argon filled (low-E, $\hat{A}_n = 0.15$, hard coat)	1.8	1.5	1.4	2.3	1.9	1.8
triple-glazed, argon filled (low-E, $\hat{A}_n = 0.1$, soft coat)	1.8	1.5	1.4	2.2	1.9	1.8
triple-glazed, argon filled (low-E, $\hat{A}_n = 0.05$, soft coat)	1.7	1.4	1.3	2.2	1.8	1.7
Windows and doors, single glazed		4.8			5.7	
Solid wooden door		3.0				

Notes:

(1) For roof windows with wooden or PVC-U frames apply the following adjustments to U-values:

Wood or PVC-U frame	U-value adjustment for roof window, W/m²K
Single glazed	+0.3
Double glazed	+0.2
Triple glazed	+0.2

(2) For windows or roof windows with metal frames apply the following adjustments to U-values:

Metal frames	Adjustment to U-value, W/m²K	
	Window	Roof window
Metal, no thermal break	+0.3	+0.7
Metal, thermal break 4 mm	0	+0.3
Metal, thermal break 8 mm	-0.1	+0.2
Metal, thermal break 12 mm	-0.2	+0.1
Metal, thermal break 20 mm	-0.3	0
Metal, thermal break 32 mm	-0.4	-0.1

(3) For doors which are half-glazed (approximately) the U-value of the door is the average of the appropriate window U-value and that of the non-glazed part of the door (e.g. solid wooden door [Uvalue of 3.0 W/m²K] half-glazed with double glazing [low-E, hard coat, argon filled, 6 mm gap, Uvalue of 2.5 W/m²K] has a resultant U-value of $0.5(3.0+2.5) = 2.75$ W/m²K).

Source: DEAP Manual Version 2.1 January 2007

Appendix C: Reference values for calculation of Maximum Permitted Energy Performance Coefficient (MPEPC) and Maximum Permitted Carbon Performance Coefficient (MPCPC)

GENERAL

C.1 This Appendix provides a set of reference values for the parameters of a DEAP calculation, which are used in connection with establishing an EPC and CPC for a dwelling for the purposes of demonstrating compliance with Regulation L2 (a) for new dwellings. [Table C1](#) is used to define a notional reference dwelling of the same size, i.e. same floor area and volume, and with the same area of opaque fabric elements, i.e. wall, roof and floor, as a dwelling being assessed. The total external window, rooflight and door area is taken to be 25% of the dwelling floor area.

C.2 The primary energy consumption and CO₂ emissions per unit floor area calculated for this reference dwelling are used to calculate the primary

energy performance coefficient (EPC) and carbon performance coefficient (CPC) respectively for a dwelling being assessed. These, in turn are compared to the MPEPC and MPCPC in order to demonstrate compliance for the dwelling being assessed.

C.3 The main heating system for space and water heating in the reference dwelling is assumed to be natural gas, while the secondary system is assumed to be an open fire. Some 10% of space heating is assumed to be provided by the secondary heating method.

<i>Table C1</i> Reference Values	
Element or system	Specifications
Total floor area, and dwelling volume	Same as actual dwelling
Opening areas (windows and doors)	25% of total floor area, or sum of exposed roof and wall area, whichever is the lesser The above includes one opaque door of area 1.85 m ² , any other doors are fully glazed
Walls	U = 0.27 W/m ² K Area : Total wall area including windows and doors to be the same as actual dwelling
Roof	U = 0.16 W/m ² K Area : Total area including any roof windows to be same as actual dwelling.
Floor	U = 0.25 W/m ² K Area : same as actual dwelling
Opaque door	U = 3.0 W/m ² K
Windows and glazed doors	U = 2.2 W/m ² K Double glazed, low-E hard coat Frame factor 0.7 Solar energy transmittance 0.72 Light transmittance 0.80
Living area fraction	Same as actual dwelling
Shading and orientation	All glazing oriented E/W; average overshadowing
Number of sheltered sides	2

<i>Table C1 (contd...)</i> Reference Values	
Element or system	Specifications
Allowance for thermal bridging	0.11 x total exposed surface area (W/K)
Internal heat capacity category	Medium
Ventilation system	Natural ventilation with intermittent extract fans
Air permeability	Infiltration due to structure = 0.5 ac/h
Chimneys	One
Open flues	None
Extract fans	3 for dwellings with floor area greater than 100 m ² , 2 for smaller dwellings
Draught lobby	None
Primary heating fuel (space and water)	Mains gas
Heating system	Boiler and radiators water pump in heated space
Boiler	Seasonal efficiency 78% room-sealed fanned flue
Heating system controls	Programmer + room thermostat + TRVs boiler interlock
Hot water system	Stored hot water, heated by boiler separate time control for space and water heating
Hot water cylinder	120 litre cylinder insulated with 35 mm of factory applied foam
Primary water heating losses	Primary pipework uninsulated cylinder temperature controlled by thermostat
Secondary space heating	Open fire
Low energy light fittings	None

Appendix D: Thermal Bridging at Junctions and Around Openings

D.1 This Appendix deals with the assessment of discrete thermal bridging not taken account of in the calculation of the U values of plane building elements, e.g. at junctions and around openings such as doors and windows. It gives guidance on

- avoidance of mould growth and surface condensation, and
- limiting factors governing additional heat losses.

The guidance is based primarily on “BRE IP 1/06: Assessing the effects of thermal bridging at junctions and around openings”.

D.2 Mould Growth and Surface Condensation

The key factor used in assessing the risk of mould growth or surface condensation in the vicinity of thermal bridges is the temperature factor (f_{Rsi}).

The temperature factor (f_{Rsi}) is defined as follows:

The temperature factor (f_{Rsi}) is defined as follows:

$$f_{Rsi} = (T_{si} - T_e) / (T_i - T_e)$$

where:

T_{si} = minimum internal surface temperature,

T_e = external temperature, and

T_i = internal temperature.

For dwellings, the value of f_{Rsi} should be greater than or equal to 0.75, so as to avoid the risk of mould growth and surface condensation. For three-dimensional corners of ground floors this value may be reduced to 0.70, for all points within 10 mm of the point of lowest f_{Rsi} .

D.3 Linear Thermal Transmittance and Additional Heat Loss

The linear thermal transmittance (ψ) describes the heat loss associated with a thermal bridge. This is a property of a thermal bridge and is the rate of heat flow per degree per unit length of bridge that is not accounted for in the U-values of the plane building elements containing the thermal bridge. The linear transmission heat loss coefficient associated with non-repeating thermal bridges is calculated as:

$$H_{TB} = \Sigma(Lx \psi) \text{ (W/m}^2\text{K)}$$

where L is the length of the thermal bridge over which ψ applies.

D.4 Calculation procedures

The calculation procedure to establish both temperature factor (f_{Rsi}) and the linear thermal transmittance (ψ) is outlined in BRE IP 1/07. Details should be assessed in accordance with the methods described in IS EN ISO 10211 Parts 1 and 2. These calculations of two dimensional or three dimensional heat flow require the use of numerical modeling software. To be acceptable, numerical modeling software should model the validation examples in IS EN ISO 10211 with results that agree with the stated values of temperature and heat flow within the tolerance indicated in the standard for these examples. Several packages are available that meet this requirement.

Detailed guidance on decisions regarding specific input to the modeling software and the determination of certain quantities from the output of the software is contained in BRE Report BR 497 *Conventions for calculating linear thermal transmittance and temperature factors*. This guidance should be followed in carrying out modeling work so that different users of the same software package and users of different software packages can obtain correct and consistent results.

Table D1 Target linear thermal transmittance (ψ) for different types of junctions.	
Junction detail in external wall	Linear Thermal Transmittance (ψ) (W/mK)
Steel lintel with perforated steel base plate	0.50
Sill	0.04
Other lintels (including other steel lintels)	0.30
Jamb	0.05
Ground floor	0.16
Intermediate floor within a dwelling	0.07
Intermediate floor between dwellings ¹	0.14
Balcony within a dwelling ²	0.00
Balcony between dwellings ^{1, 2}	0.04
Eaves (insulation at ceiling level)	0.06
Eaves (insulation at rafter level)	0.04
Gable (insulation at ceiling level)	0.24
Gable (insulation at rafter level)	0.04
Corner (normal)	0.09
Corner (inverted)	-0.09
Party wall between dwellings ¹	0.06

Note 1: For these junctions, half the value of ψ is applied to each dwelling

Note 2: Refers to an externally supported balcony (the balcony slab is not a continuation of the floor slab)

D.5 Values of linear thermal transmittance (ψ)

Table D1 sets out a set of target values for typical key thermal bridges encountered in dwellings. Thermal bridges which are in accordance with those contained “*Accredited Details*” (downloadable from Department of Communities and Local Government (London) website [www. Communities.gov.uk](http://www.Communities.gov.uk)) or the document “*Limiting Thermal Bridging and Air Infiltration – Acceptable Construction Details*” (to be published) satisfy these target values.

D.6 Treatment of Thermal Bridging in DEAP calculation

Heat loss through thermal bridging is taken account of in the DEAP calculation. Two alternative methods of accounting for heat loss are possible

- (a) Heat loss through thermal bridging can be accounted for in terms of a fraction (y) multiplied by the exposed surface area of the building. Where the linear thermal transmittance (ψ) of all the construction details used are known to meet the target values set out in Table D1, or are shown by calculation to meet these values, the value of (y) can be taken as 0.8. Where this is not the case, but this method of accounting for thermal bridging is used, the default value of (y) of is taken to be 0.15.
- (b) Values of ψ can be determined from the results of numerical modeling, or they can be derived from measurement. The linear transmission heat loss coefficient (H_{TB}) can then be calculated directly and included in the DEAP calculation.

The approach adopted is fully explained in the DEAP manual.

Appendix E: Achieving Compliance with respect to EPC and CPC

EI The following table gives a set of specifications which are calculated to achieve compliance for a typical 126 m² semi-detached house. Compliance with this requirement could also be achieved by a number of other combinations of measures.

<i>Table E1</i> Example Dwellings	
Element or system	Specifications
Dwelling size and shape	Semi-detached house, two-storey Overall internal dimensions: 7 m wide x 9 m deep x 5.1 m high Total floor area 126 m ² Rectangular shape with no irregularities
Opening areas (windows and doors)	25% of total floor area The above includes one opaque door of area 1.85 m ² , any other doors are fully glazed
Walls	U = 0.25 W/m ² K e.g. cavity wall with 100 mm insulation of conductivity 0.03 W/m K in cavity
Roof	U = 0.15 W/m ² K e.g. 270 mm insulation of conductivity 0.04 W/m K, between and over ceiling joists
Floor	U = 0.20 W/m ² K e.g. Slab-on-ground floor with 100 mm insulation of conductivity 0.03 W/m K
Opaque door	U = 3.0 W/m ² K
Windows and glazed doors	Double glazed, low E (E _n = 0.05, soft coat) 16mm gap, argon filled, wood frames (U = 1.7 W/m ² K, solar transmittance = 0.63)
Living area fraction	25% of total floor area
Shading and orientation	All glazing oriented E/W; average overshading
Number of sheltered sides	2
Allowance for thermal bridging at element junctions	0.08 x total exposed surface area (W/m ² K)
Internal heat capacity category	Medium
Ventilation system	Natural ventilation with intermittent extract fans
Air permeability	Infiltration due to structure = 0.4 ac/h
Chimneys	None
Open flues	None
Extract fans	3

<i>Table E1 (contd...)</i> Example Dwelling	
Element or system	Specifications
Draught lobby	None
Primary heating fuel (space and water)	Mains gas
Heating system	Boiler and radiators water pump in heated space
Boiler	Mains gas condensing boiler, seasonal efficiency 90%, room-sealed, fanned flue
Heating system controls	Programmer + room thermostat + TRVs, boiler interlock
Hot water system	Solar water heating system with flat plate collector of aperture area = 3.8 m ² , $\eta^0 = 0.8$, $a^1 = 5.0 \text{ W/m}^2 \text{ K}$, facing SE/SW at 30 degrees and unshaded, twin coil cylinder 250 litre with 75 mm insulation Remainder of demand met by space heating boiler, separate time control for space and water heating, cylinder temperature controlled by thermostat
Primary water heating losses	Insulated primary pipework between boiler and cylinder
Secondary space heating	Gas fire, closed front, fan assisted, balanced flue – efficiency 72%
Low energy light fittings	75%

E.2 The standardized primary energy consumption and CO₂ emissions for space heating, water heating, ventilation and lighting for this dwelling, as calculated by DEAP, are given in [Table E2](#), expressed per m² of floor area per annum. The table shows that the calculated EPC just complies with the MPEPC requirement of 0.60, and the CPC complies with the MPCPC requirement of 0.69 with a margin to spare.

If the boiler ran on heating oil rather than mains gas, and the secondary heater on bottled LPG, with the same efficiencies as above, the dwelling would be slightly outside compliance. Compliance may be achieved, for example, by improving the roof U-value from 0.15 to 0.13. The results following this change are also shown in the [Table E2](#).

<i>Table E2</i> Example Dwelling - Results		
	Dwelling heated by mains gas	Dwelling heated by oil (with secondary heating by LPG)
Primary energy [kWh/m ² yr]	90	90
CO ₂ emissions [kg/m ² yr]	18	22
EPC	0.60	0.60
CPC	0.55	0.68

Standards and Other References

Standards referred to:

I.S. 161: 1975 Copper direct cylinders for domestic purposes.

I.S. 325-1: 1986 Code of Practice for use of masonry - part 1: Structural use of unreinforced masonry.

I.S. EN 1745: 2002 Masonry And Masonry Products - Methods for determining Design Thermal Values.

I.S. EN ISO 6946: 1997 Building components and building elements –Thermal resistance and thermal transmittance – Calculation method Amd 1 2003.

I.S. EN ISO 8990: 1997 Thermal insulation – Determination of steady-state thermal transmission properties – Calibrated and guarded hot box.

I.S. EN ISO 10077-1: 2001 Thermal performance of windows, doors and shutters – Calculation of thermal transmittance – Part 1: simplified method.

I.S. EN 10077-2: 2000 Thermal performance of windows, doors and shutters – Calculation of thermal transmittance – Part 2: Numerical methods for frames.

I.S. EN ISO 10211-1: 1996 Thermal bridges in building construction – heat flows and surface temperatures. Part 1 general calculation methods.

I.S. EN ISO 10211-2: 2001 Thermal bridges in building construction – heat flows and surface temperatures. Part 2 linear thermal bridges.

I.S. EN ISO 10456: 2000 Building materials and products - procedures for determining declared and design thermal values.

I.S. EN 12524: 2000 Building materials and products – Hygrothermal properties – Tabulated design values.

I.S. EN ISO 12567-1: 2001 Thermal performance of windows and doors – Determination of thermal transmittance by hot box method – Part 1: Complete windows and doors.

I.S. EN ISO 13370: 1999 Thermal performance of buildings – Heat transfer via the ground – Calculation methods.

I.S. EN ISO 13789: 2000 Thermal Performance of Buildings – Transmission Heat Loss Coefficient – Calculation Method.

I.S. EN 13829: 2000 Thermal Performance of Buildings: Determination of air permeability of buildings: fan pressurisation method.

BS 747: 2000 Reinforced bitumen sheets for roofing – Specification.

BS 1566 Part 1: 2002 Copper indirect cylinders for domestic purposes, open vented copper cylinders. Requirements and test methods.

BS 5422 : 2001 Method for specifying thermal insulating materials for pipes, tanks, vessels, ductwork

and equipment (operating within the temperature range - 400C to + 7000C).

BS 8206 Part 2: 1992 Lighting for buildings. Code of practice for daylighting.

Other Publications referred to:

BRE Digest 465, U-values for light steel frame construction, BRE, 2002.

BRE Information Paper I/06 Assessing the effects of thermal bridging at junctions and around openings, BRE, 2001.

BRE Information Paper 10/02, Metal cladding: assessing the thermal performance of built-up systems using 'Z' spacers, BRE, 2002

BRE Report BR 262, Thermal Insulation: avoiding risks, BRE, 2001

BRE Report BR 364, Solar shading of buildings, BRE, 1999

BRE Report BR 443, Conventions for U-value Calculations, BRE, 2002.

BRE Report BR 497, Conventions for calculating linear thermal transmittance and temperature factors, BRE, 2007

CIBSE Guide A: Environmental Design - Section 3: Thermal Properties of Buildings and Components, CIBSE, 1999

CIBSE TM 23: Testing Buildings for Air Leakage, CIBSE, 2000

Chris Knights and Nigel Potter, Airtightness Testing for New Dwellings, A BSRIA Guide ,BSRIA, 2006

Domestic Energy Assessment Procedure (DEAP) SEI 2006 (www.sei.ie)

Good Practice Guide 268, Energy efficient ventilation in dwellings – a guide for specifiers, 2006

Home-heating Appliance Register of Performance (HARP) database, SEI (www.sei.ie/harp).

Heating and Domestic Hot Water Systems for dwellings – Achieving compliance with Part L (to be published).

Limiting Thermal Bridging and Air Infiltration – Acceptable Construction Details (to be published)

MCRMA Technical Paper No. 14, Guidance for the design of metal roofing and cladding to comply with Approved Document L2:2001, The Metal Cladding and Roofing Manufacturers Association, 2002

SCI Technical Information Sheet 312, Metal cladding: U-value calculation - assessing thermal performance of built-up metal roof and wall cladding systems using rail and bracket spacers, The Steel Construction Institute, 2002

SI. No. 260 of 1994, European Communities (Efficiency requirements for hot water boilers fired with liquid or gaseous fuels) Regulations, 1994, The Department of Transport, Energy and Communications, 1994

Other Useful Standards and Publications

IS EN 14785: 2006 Residential space heating appliances fired by wood pellets - requirements and test methods

I.S. EN 303-5: 1999 Heating boilers - heating boilers for solid fuels, hand and automatically stoked, nominal heat output of up to 300 kw - terminology requirements, testing and marking

Pr EN 15270: Pellet burners for small heating boilers - Definitions, requirements, testing, marking (Expected to be adopted as IS EN 15270 in 2008)

IS EN 12975-1: 2006 Thermal solar systems and components - solar collectors - part 1: general requirements

IS EN 12975-2: 2006 Thermal solar systems and components - solar collectors - part 2: test methods

IS EN 12976-1: 2006 Thermal solar systems and components - factory made systems - part 1: general requirements

IS EN 12976-2 : 2006 Thermal solar systems and components - factory made systems - part 2: test methods

IS ENV 12977-1: 2001 Thermal solar systems and components - custom built systems - part 1: general requirements

IS ENV 12977-2 : 2001 Thermal solar systems and components - custom built systems - part 2: test methods

ISO 9806-1: 1994 Test methods for solar collectors - part 1: thermal performance of glazed liquid heating collectors including pressure drop

ISO 9806-2: 1995 Test methods for solar collectors - part 2: qualification test procedures

ISO 9806-3: 1995 Test methods for solar collectors - part 3: thermal performance of unglazed liquid heating collectors (sensible heat transfer only) including pressure drop

IS EN 14511-1: 2004 Air conditioners, liquid chilling packages and heat pumps with electrically driven compressors for space heating and cooling - part 1: terms and definitions

IS EN 14511-2 :2004 Air conditioners, liquid chilling packages and heat pumps with electrically driven compressors for space heating and cooling - part 2: test conditions

IS EN 14511-3: 2004 Air conditioners, liquid chilling packages and heat pumps with electrically driven compressors for space heating and cooling - part 3: test methods

IS EN 14511-4: 2004 Air conditioners, liquid chilling packages and heat pumps with electrically driven compressors for space heating and cooling - part 4: requirements

I.S. EN 12664: 2001 Thermal performance of building materials and products – Determination of thermal resistance by means of guarded hot plate and heat flow meters method – Dry and moist products of low and medium thermal resistance.

I.S. EN 12667: 2001 Thermal performance of building materials and products – Determination of thermal resistance by means of guarded hot plate and heat flow meters method – Products of high and medium thermal resistance.

I.S. EN 12828: 2003 Heating systems in buildings - design for water-based heating systems.

I.S. EN 12939: 2001 Thermal performance of building materials and products – Determination of thermal resistance by means of guarded hot plate and heat flow meters method – Thick products of high and medium thermal resistance.



Printed on recycled paper
containing a minimum of
75% post-consumer waste

30-01 03/08 (3,000) Brunswick Press Ltd. (20426)

ISBN 978-1-4064-2123-1



9 781406 421231